

CLOSET CARRIER

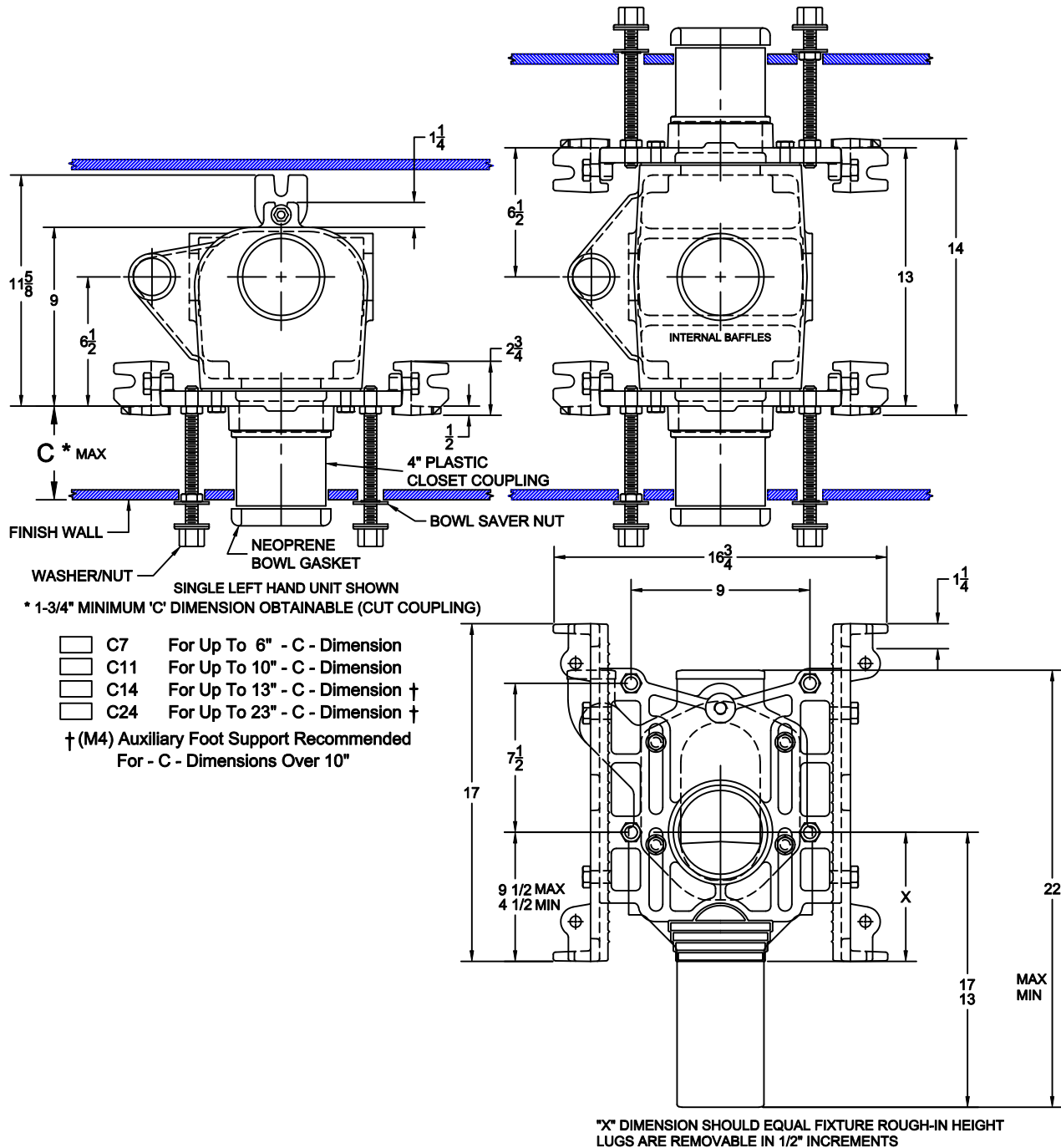

ADJUSTABLE CARRIER INSTALLATION GUIDE

FEATURES OF STANDARD VERTICAL WATER CLOSET CARRIERS
330 ILLUSTRATED



- C7 For Up To 6" - C - Dimension
 - C11 For Up To 10" - C - Dimension
 - C14 For Up To 13" - C - Dimension †
 - C24 For Up To 23" - C - Dimension †
- † (M4) Auxiliary Foot Support Recommended For - C - Dimensions Over 10"

CLOSET CARRIER



ADJUSTABLE CARRIER INSTALLATION GUIDE

FEATURES OF STANDARD HORIZONTAL WATER CLOSET CARRIERS
310 ILLUSTRATED

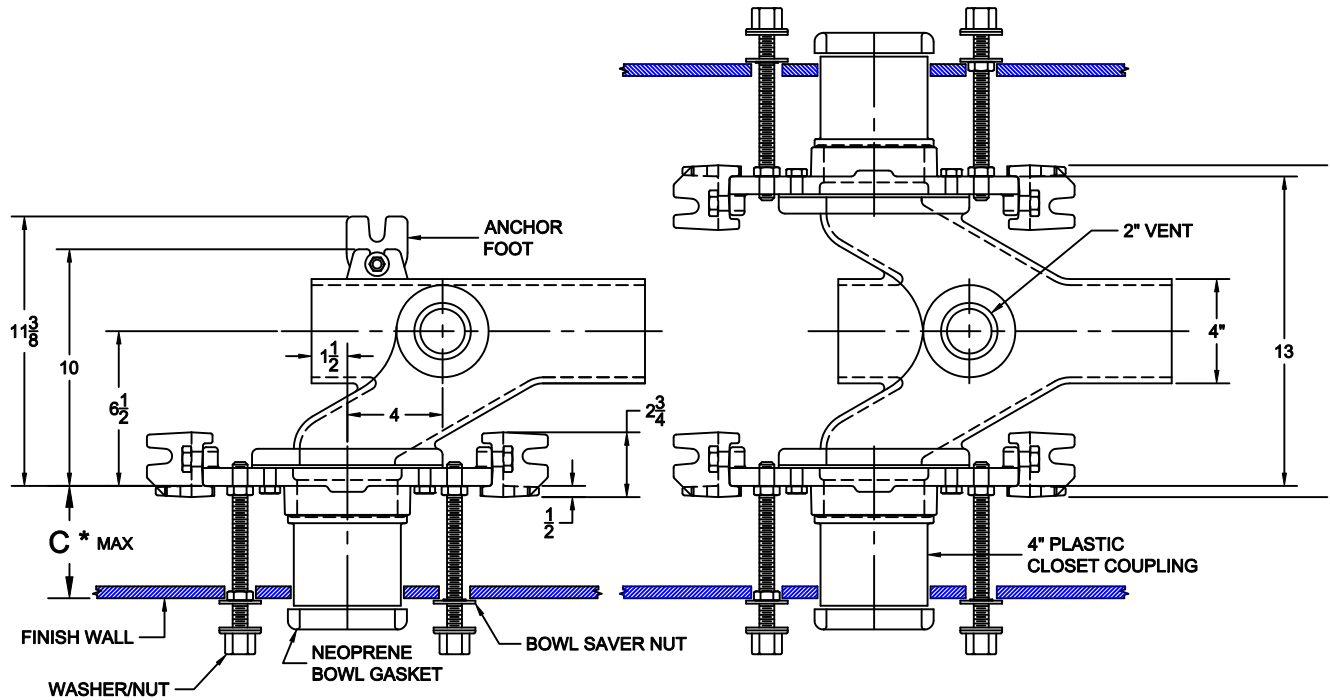

* 1-3/4" MINIMUM 'C' DIMENSION OBTAINABLE (CUT COUPLING)

- C7 For Up To 6" - C - Dimension
- C11 For Up To 10" - C - Dimension
- C14 For Up To 13" - C - Dimension †
- C24 For Up To 23" - C - Dimension †

† (M4) Auxiliary Foot Support Recommended For - C - Dimensions Over 10"

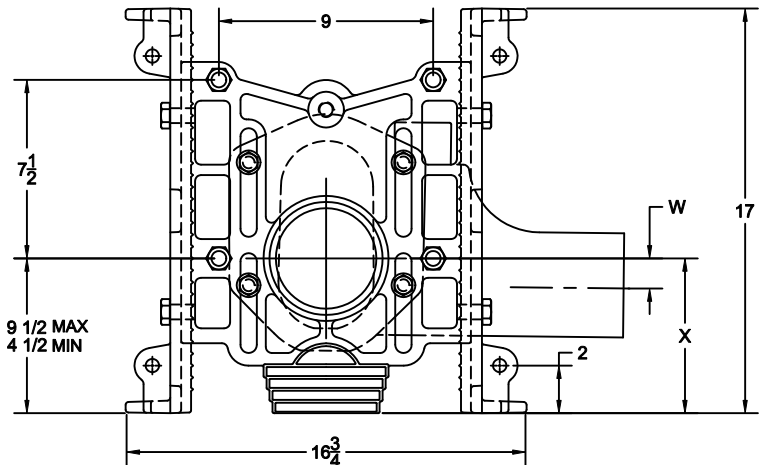

W - DIMENSION		
MIN	MAX	TYPE
0	4"	SIPHON JET

"X" DIMENSION SHOULD EQUAL FIXTURE ROUGH-IN HEIGHT
LUGS ARE REMOVABLE IN 1/2" INCREMENTS

CLOSET CARRIER



ADJUSTABLE CARRIER INSTALLATION GUIDE

STEP 1

DETERMINE STYLE OF CARRIER FITTING TO BE USED

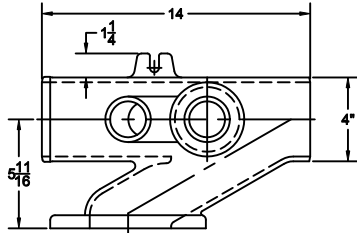

670610 378242 310-NHL-UA
LEFT HAND SGL HORIZONTAL CARRIER FITTING

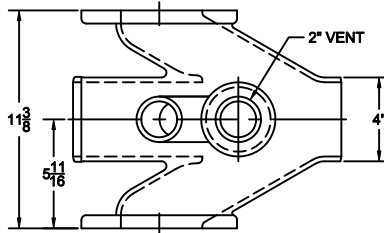

670610 378266 310-NHD-UA
DOUBLE HORIZONTAL CARRIER FITTING

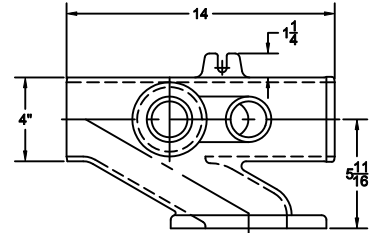

670610 378259 310-NHD-UA
RIGHT HAND SGL HORIZONTAL CARRIER FITTING

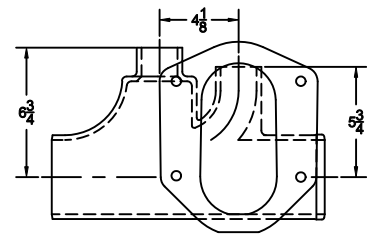
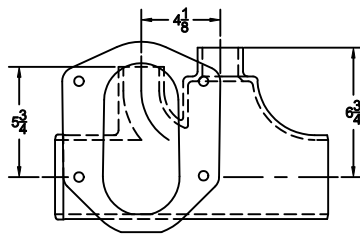
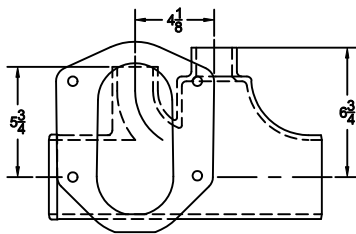

670610 420323 300-NHL
LEFT HAND SGL HORIZONTAL CARRIER FITTING

670610 320330 300-NHD
DOUBLE HORIZONTAL CARRIER FITTING

670610 420347 300-NHR
RIGHT HAND SGL HORIZONTAL CARRIER FITTING

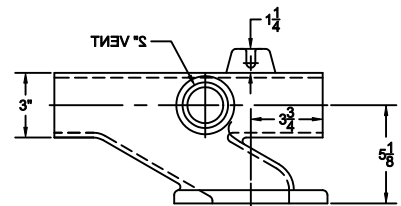
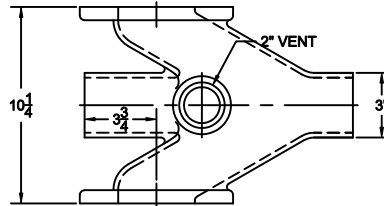
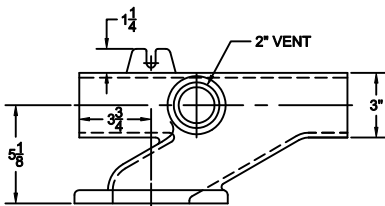

670610 420323 300-NHL
LEFT HAND SGL HORIZONTAL CARRIER FITTING

670610 320330 300-NHD
DOUBLE HORIZONTAL CARRIER FITTING

670610 420347 300-NHR
RIGHT HAND SGL HORIZONTAL CARRIER FITTING

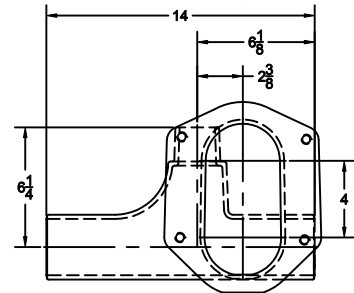
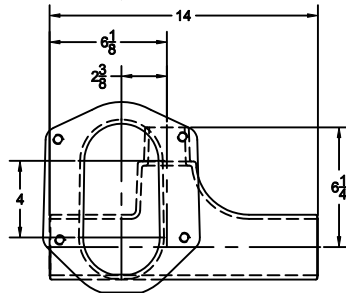
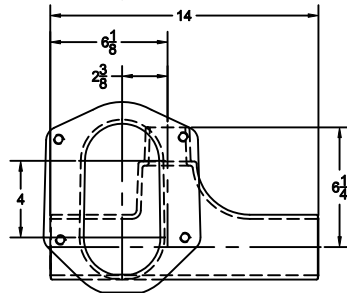

CLOSET CARRIER



ADJUSTABLE CARRIER INSTALLATION GUIDE

STEP 1

DETERMINE STYLE OF CARRIER FITTING TO BE USED

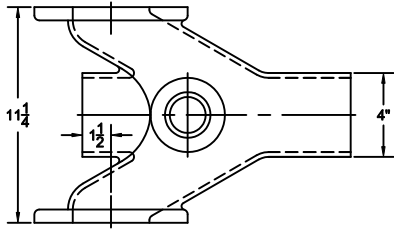

670610 379775 310-NHD
DBL HORIZONTAL CARRIER FITTING

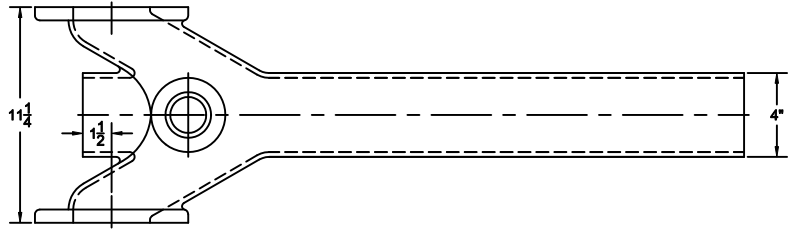

670610 378792 310-NHD-36
DBL EXTENDED HORIZONTAL CARRIER FITTING

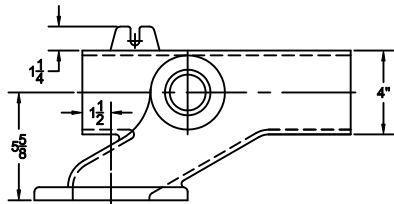

670610 379751 310-NHL
LEFT HAND SGL HORIZONTAL CARRIER FITTING

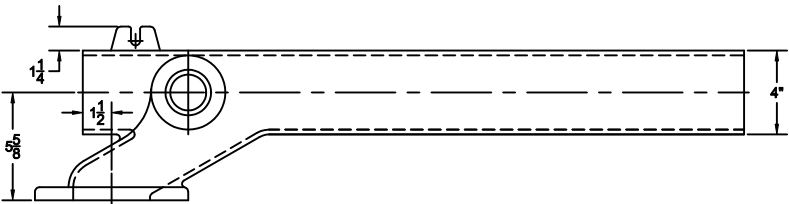

670610 378778 310-NHD-36
RIGHT HAND SGL EXTENDED HORIZONTAL CARRIER FITTING

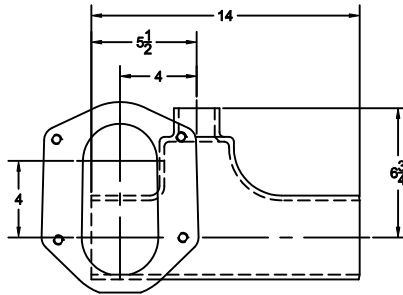

670610 378785 310-NHR-36
RIGHT HAND EXTENDED SGL HORIZONTAL CARRIER FITTING

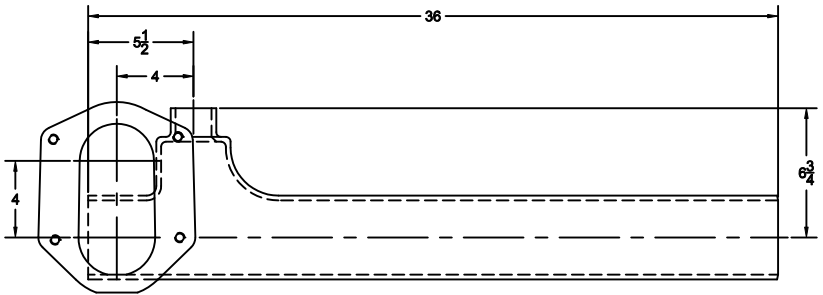

670610 379768 310-NHR
RIGHT HAND EXTENDED SGL HORIZONTAL CARRIER FITTING

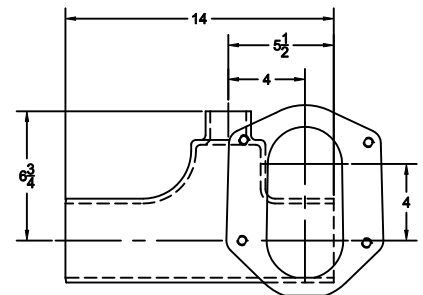
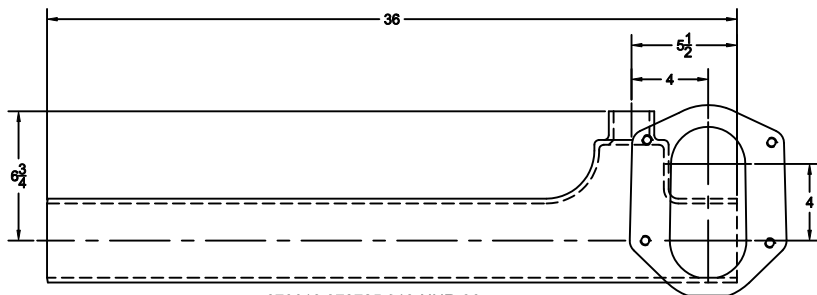

CLOSET CARRIER



ADJUSTABLE CARRIER INSTALLATION GUIDE

STEP 1

DETERMINE STYLE OF CARRIER FITTING TO BE USED

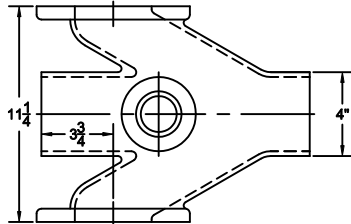

670610 408529 320-NHD
DBL HORIZONTAL CARRIER FITTING

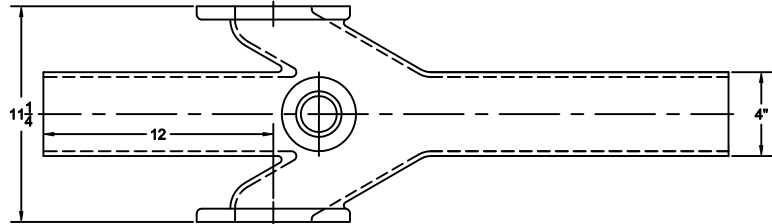

670610 408529 310-NHD-36
DBL EXTENDED HORIZONTAL CARRIER FITTING

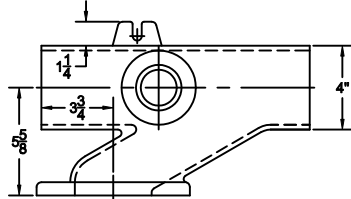

670610 408536 320-NHL
LEFT HAND SGL HORIZONTAL CARRIER FITTING

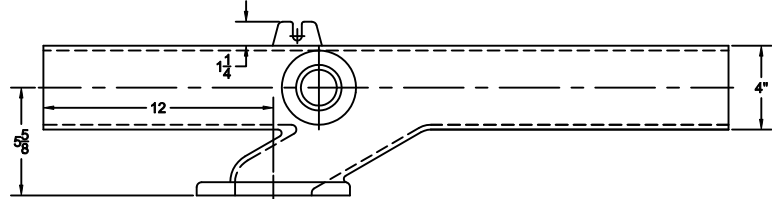

670610 408536 320-NHD-36
LEFT HAND SGL EXTENDED HORIZONTAL CARRIER FITTING

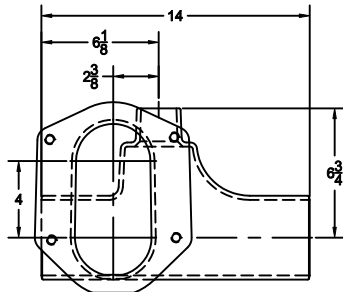

670610 434504 320-NHR-36
RIGHT HAND EXTENDED SGL HORIZONTAL CARRIER FITTING

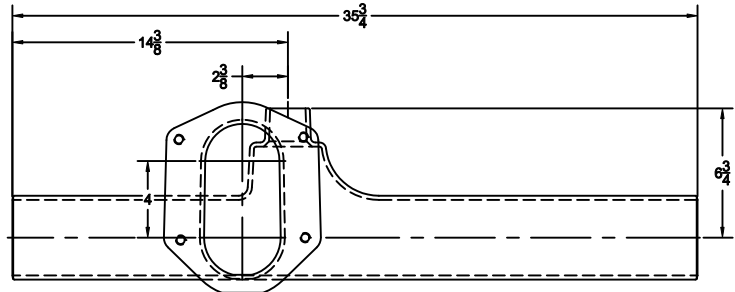

670610 408543 320-NHR
RIGHT HAND EXTENDED SGL HORIZONTAL CARRIER FITTING

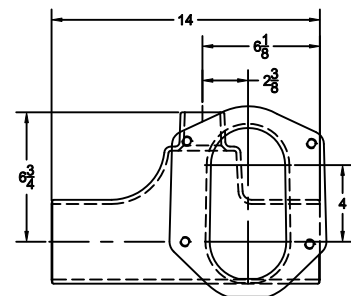
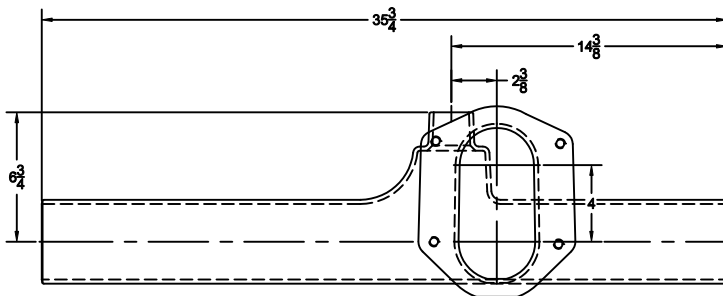

CLOSET CARRIER



ADJUSTABLE CARRIER INSTALLATION GUIDE

STEP 1

DETERMINE STYLE OF CARRIER FITTING TO BE USED

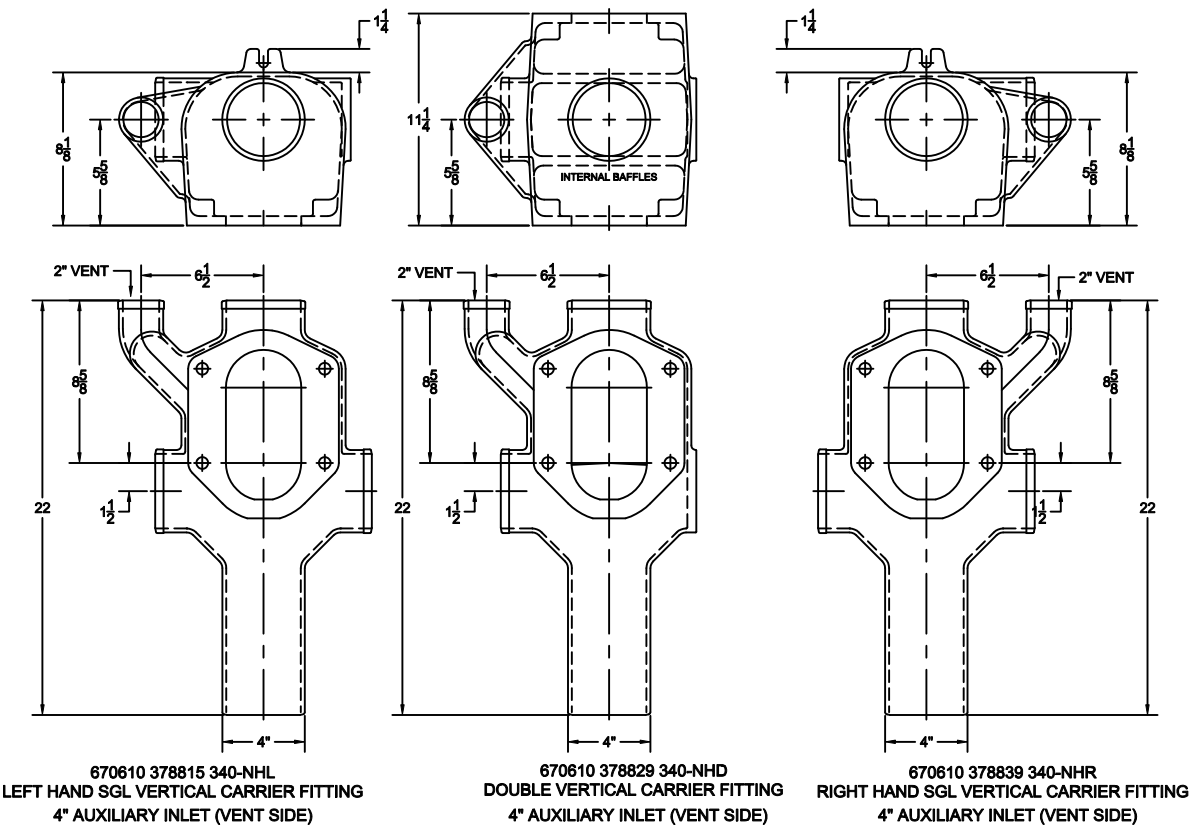
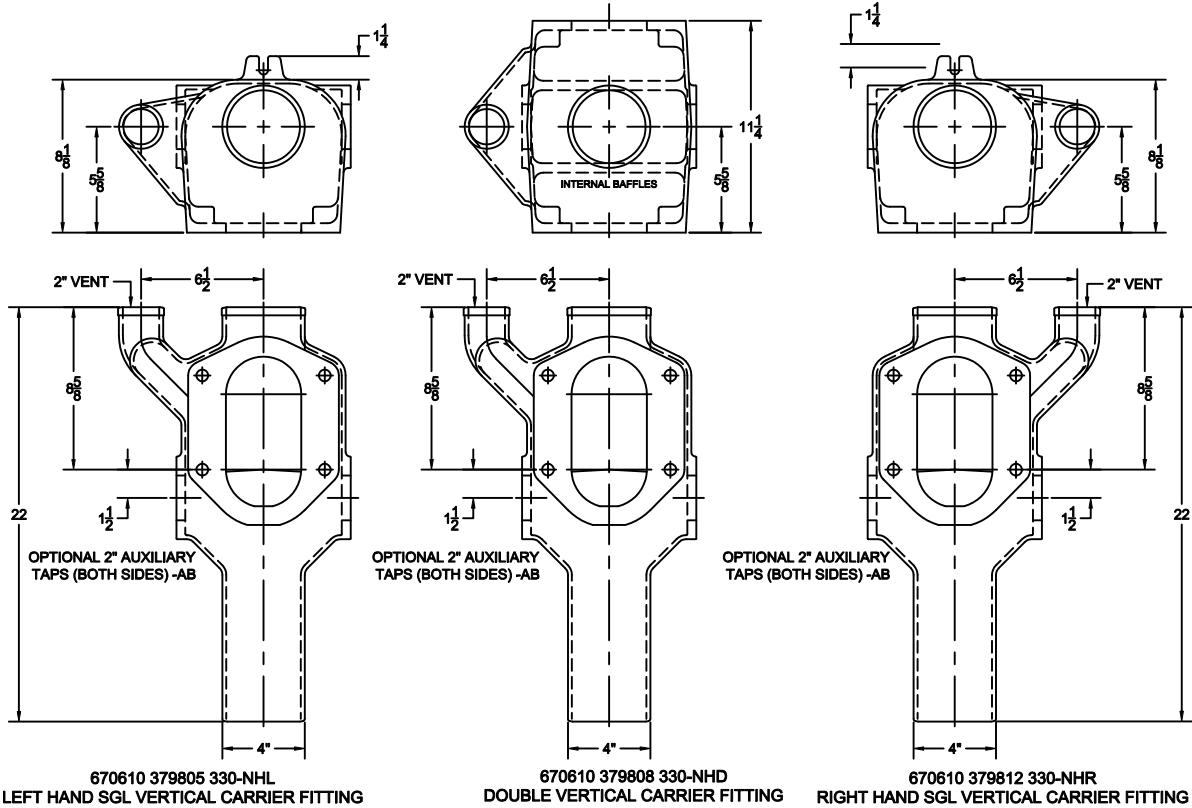

CLOSET CARRIER



ADJUSTABLE CARRIER INSTALLATION GUIDE

STEP 1

DETERMINE STYLE OF CARRIER FITTING TO BE USED

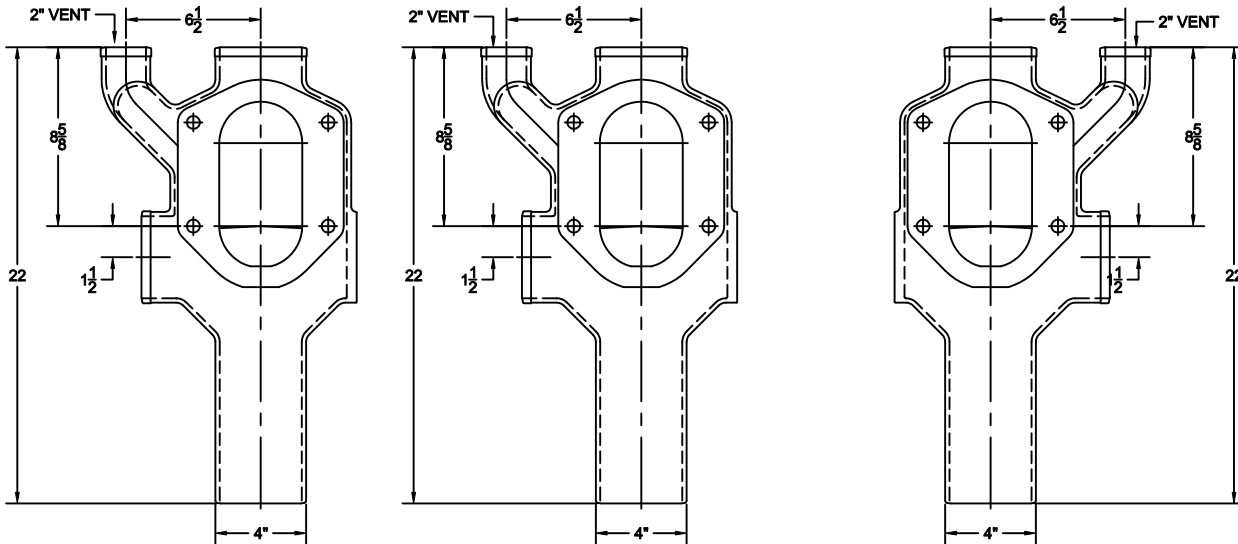
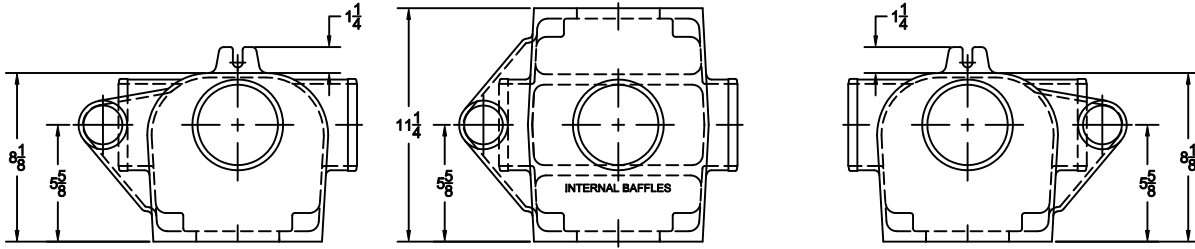

670610 379805 330-NHL
LEFT HAND SGL VERTICAL CARRIER FITTING
(2) 4" AUXILIARY INLETS

670610 379808 330-NHD
DOUBLE VERTICAL CARRIER FITTING
(2) 4" AUXILIARY INLETS

670610 379812 330-NHR
RIGHT HAND SGL VERTICAL CARRIER FITTING
(2) 4" AUXILIARY INLETS

STEP 2

VERIFY ALL COMPONENTS FOR THE FACE PLATE ASSEMBLY

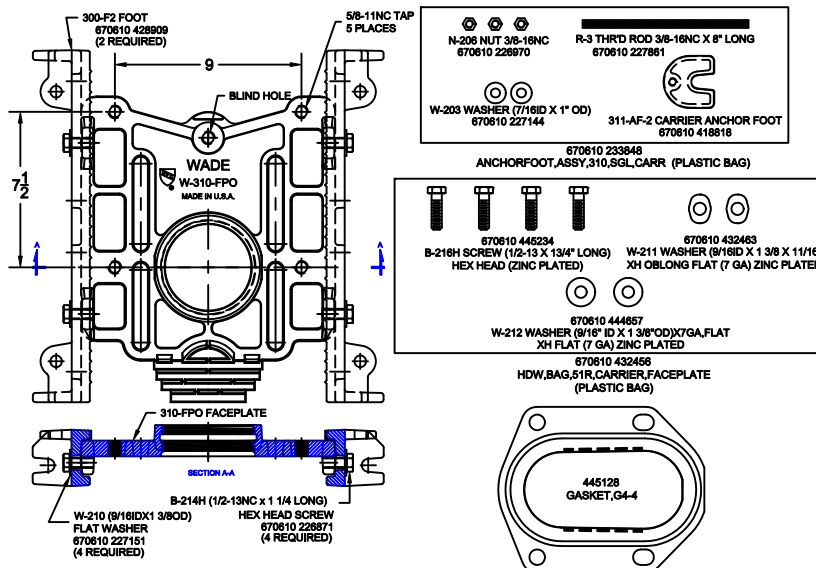

CLOSET CARRIER



ADJUSTABLE CARRIER INSTALLATION GUIDE

STEP 3 DETERMINE COUPLING PACKAGE TO BE USED

7" STANDARD COUPLING PACKAGE

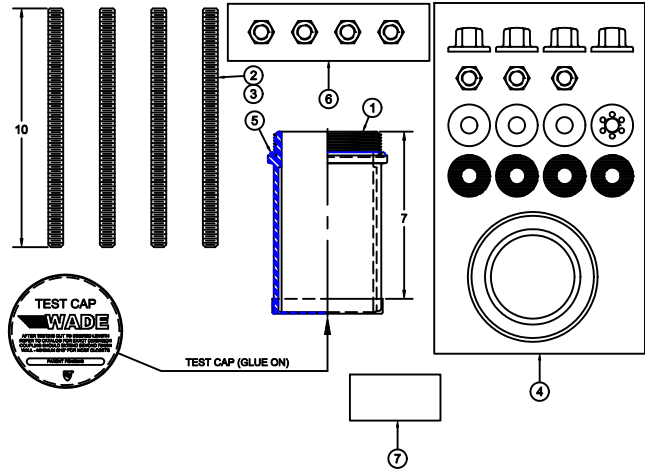

NO	UPC NUMBER	QTY	DESCRIPTION
1	670610 408686	1	CLOSET COUPLING P7 4IN PLASTIC
2	670610 227922	4	THREADED ROD R14 5/8-11NC X 10" LONG
3	670610 228790	4	PLASTIC SLEEVE M28
4	670610 300465	1	FINISH HARDWARE BAG 1FA
5	670610 407515	1	NEOPRENE O-RING GASKET GD-63
6	670610 228264	1	HARDWARE BAG 18CA
7	670610 383024	1	O-RING LUBRICANT

11" STANDARD COUPLING PACKAGE

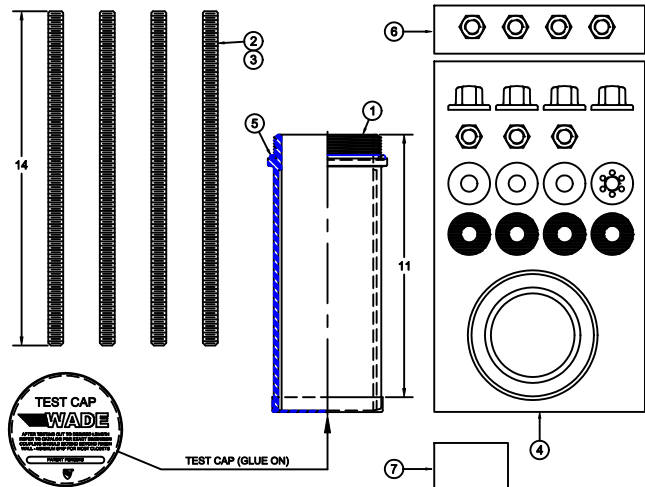

NO	UPC NUMBER	QTY	DESCRIPTION
1	670610 408673	1	CLOSET COUPLING P11 4IN PLASTIC
2	670610 408741	4	THREADED ROD R45 5/8-11NC X 14" LONG
3	670610 228790	4	PLASTIC SLEEVE M28
4	670610 300465	1	FINISH HARDWARE BAG 1FA
5	670610 407515	1	NEOPRENE O-RING GASKET GD-63
6	670610 228264	1	HARDWARE BAG 18CA
7	670610 383024	1	O-RING LUBRICANT

14" STANDARD COUPLING PACKAGE

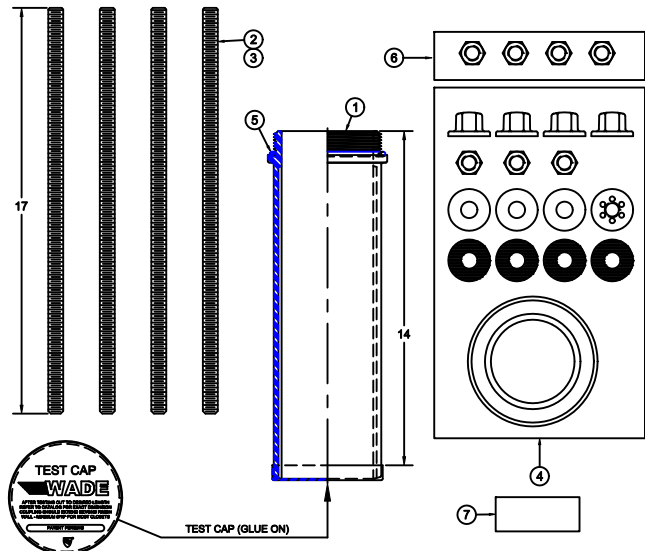

NO	UPC NUMBER	QTY	DESCRIPTION
1	670610 408680	1	CLOSET COUPLING P14 4IN PLASTIC
2	670610 408758	4	THREADED ROD R46 5/8-11NC X 17" LONG
3	670610 228790	4	PLASTIC SLEEVE M28
4	670610 300465	1	FINISH HARDWARE BAG 1FA
5	670610 407515	1	NEOPRENE O-RING GASKET GD-63
6	670610 228264	1	HARDWARE BAG 18CA
7	670610 383024	1	O-RING LUBRICANT

ADJUSTABLE CARRIER INSTALLATION GUIDE

STEP 3

DETERMINE COUPLING PACKAGE TO BE USED

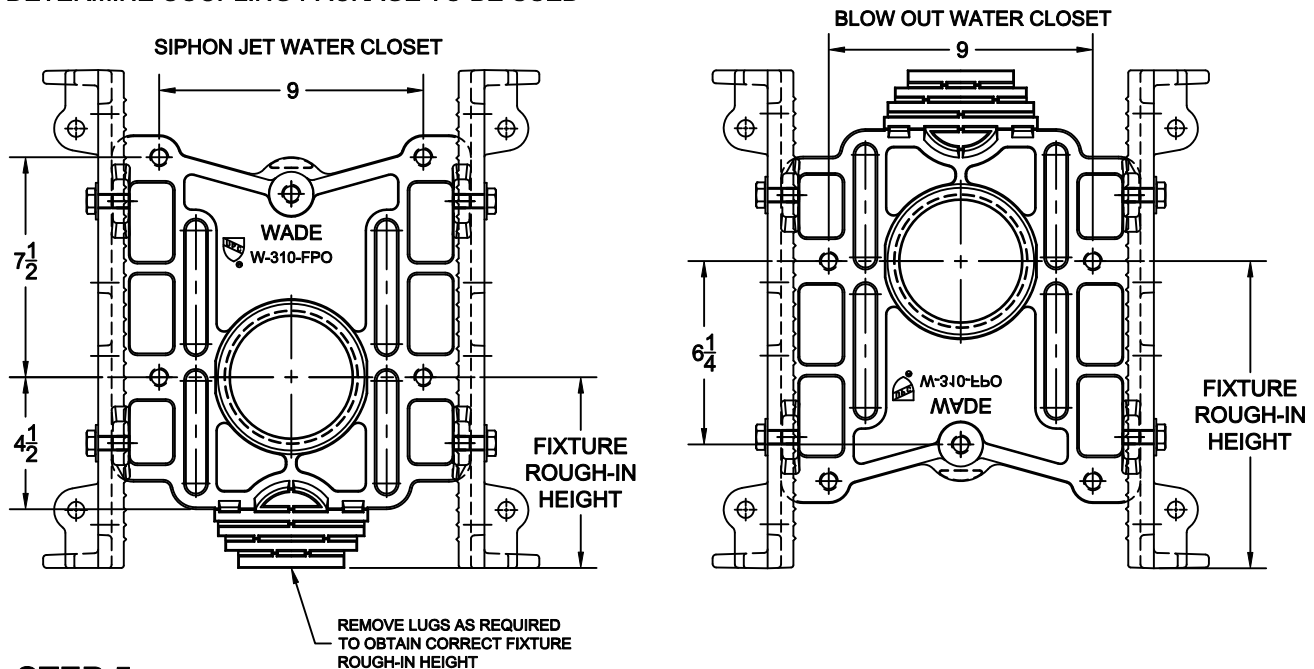

STEP 5

If the carrier fittings to be used are horizontal style, lay out all the necessary fittings on the floor. To obtain spacing between the units, place proper lengths of pipe between adjoining fittings (or use extended fittings).

STEP 6

Using Tyler No-Hub couplings, make up the fitting to pipe connections and tighten with a Tyler torque wrench. Make sure all the fitting face plates are parallel.

STEP 7

Roll the entire assembly of the connected fittings and drainage pipe 180 degrees so that the fitting faces are up.

STEP 8

From the face plate assembly boxes, remove and install the faceplate gaskets onto the fittings - locator ribs on the gaskets are used to properly align the gasket into the oval opening of the fitting. Insure the four holes in the gasket align with the drill and tapped holes in the carrier fitting.

STEP 9

Determine from the fixture manufacturer's rough-in sheet the style of fixture - Siphon Jet or Blow-Out. (See Illustration Above for Proper Orientation). If Siphon-Jet water closets are to be used, determine recommended rough-in height to the closet horn. Remove lugs on the bottom of the faceplate to achieve correct height.

STEP 10

Bolt face plates onto fittings with the provided hardware - Oblong washer are used on the bottom two holes (adjacent to the faceplate threaded horn). Hand tighten.

ADJUSTABLE CARRIER INSTALLATION GUIDE

STEP 11

Adjust feet on face plate assemblies so that the bottom of the feet are parallel to the bottom of the faceplate and on the same plane. Securely tighten the bolts that secure the feet with a wrench. The openings on successive fittings should be located at successively lower positions to maintain proper drainage pitch - after this adjustment is made, tighten all the bolts uniformly until the gasket is sufficiently compressed.

STEP 12

Roll the entire assembly 90 degrees forward onto the feet, move into the desired position, level, align and make the stack connection. Secure feet to concrete floor with 1/2" anchors (supplied by others)

STEP 13

If the units are single fittings, install the rear anchor foot assembly. To assemble, screw the stud (threaded rod) into the cast foot and secure with the locknut. Slide this assembly into position with the anchor slot on the rear of the carrier fitting. Secure with two flat washers and hex nuts - adjust as need to allow the cast foot to remain in contact with the concrete floor. Securely fasten the cast foot to the floor with 1/2" anchors.

STEP 14

At this point the closet coupling and 5/8" threaded studs can be installed. Insure the surfaces are clean - lubricate the o-ring and install over the male threaded end of the 4" plastic closet coupling - screw the coupling into the face plate until the o-ring contacts the horn - hand tighten. Using the four 5/8" hex jam nuts provided, install onto the threaded studs then screw into the threaded holes on the faceplate. Tighten the jam nuts with a wrench. Make sure the plastic sleeves are over the studs. It is recommended that a sleeve be placed around the coupling to keep mortar from locking the coupling into the wall, thus allowing the coupling to be removed after the finished wall is up.

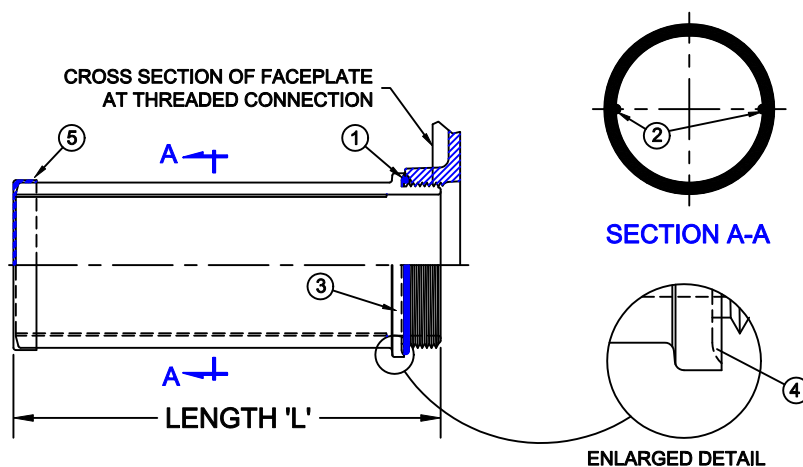

CATALOG NUMBER	L
C7	7 1/2
C11	11 1/2
C14	14 1/2
C24	24 1/2

- ① NEOPRENE O-RING SEAL
- ② LINEAR GROOVES FOR WRENCH ADJUSTMENT
- ③ INTEGRAL SEALING FLANGE
- ④ RECESS FOR O-RING SEAL CONTAINMENT
- ⑤ INTEGRAL TEST CAP

ADJUSTABLE CARRIER INSTALLATION GUIDE

STEP 15

After the finished wall is complete, install backup nuts and washers onto the top two fixture support studs and one of the bottom fixture support studs - the remaining stud receives the provided "Bowl Saver Nut". The studs and closet coupling can now be cut to length. Due to the variations in gasket recesses and the thickness of the water closet flanges on various fixtures, it is important to check all coupling and stud dimensional data using the formulas illustrated below. If the studs are too long, they will bottom in the cap nuts before the closet has been drawn up sufficiently to compress the bowl gasket. The coupling should extend far enough beyond the finished wall so that the the gasket will compress into the fixture recess to provide a leak proof seal.

STEP 16

After the fixture support studs and closet coupling have been adjusted to the proper dimensions, install the bowl gasket onto the coupling. Adjust the backup nuts/washers to allow a slight gap (1/16") between the fixture and finished wall (after installation) - The bowl saver nut should be adjusted further back. Install the fixture, aligning the holes with the support studs and insuring the gasket seats into the fixture recess, then install cap nuts on the three studs with backup nuts/washers. Tighten securely. With a drift pin or nail, reach into the cavity between the fixture hole and support stud to contact the bowl saver nut and rotate to bring the washer into contact with the fixture flange. Install the remaining cap nut and tighten.

Special Note: The carrier is designed to support the fixture independently of the wall and must be secured to a floor substantial enough for support. The piping must be supported by other means.

