

PARKING DECK DRAIN



Approval
Date

Customer
Approval

Job
Location

Job
Name

Dimensional Data (Inches/mm) are Subject to Manufacturers Tolerance and Change Without Notice. Wade Division / Tyler Pipe Assumes No Responsibility For Superseded or Voided Data

2360

CAST IRON PARKING DECK DRAIN WITH SQUARE TOP, DUCTILE IRON GRATE, CLAMPING COLLAR, SEDIMENT BUCKET AND BOTTOM OUTLET.
INSTALLATION INSTRUCTIONS

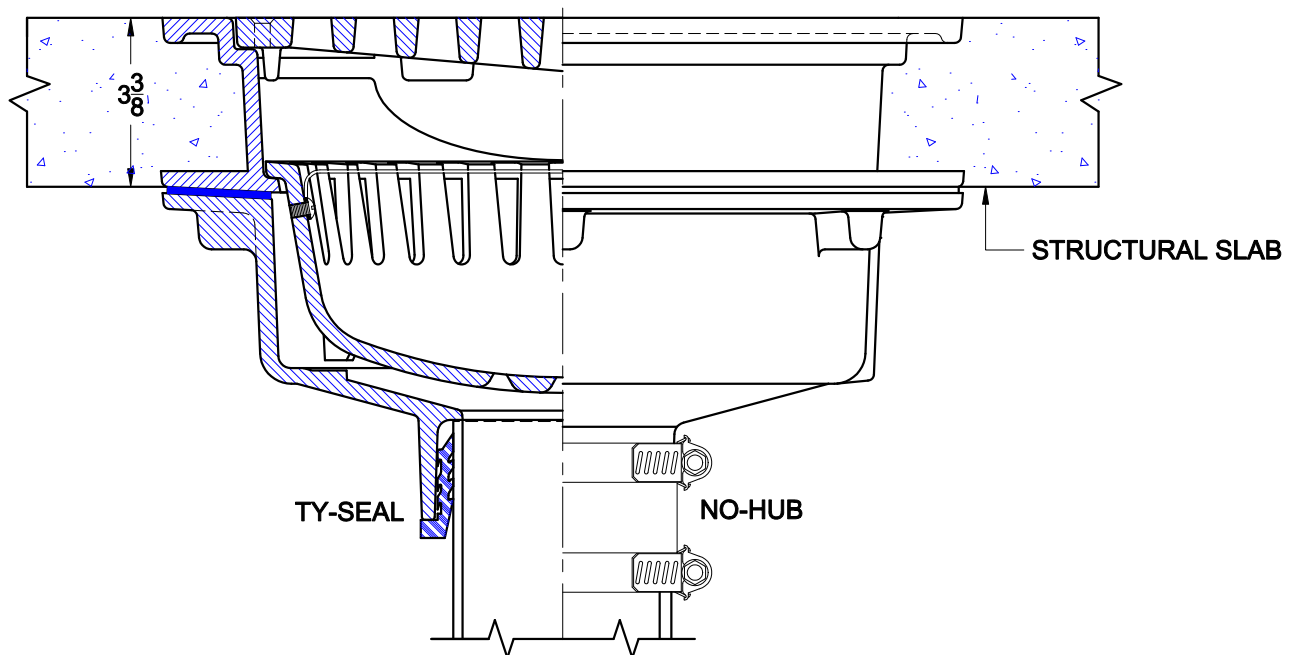
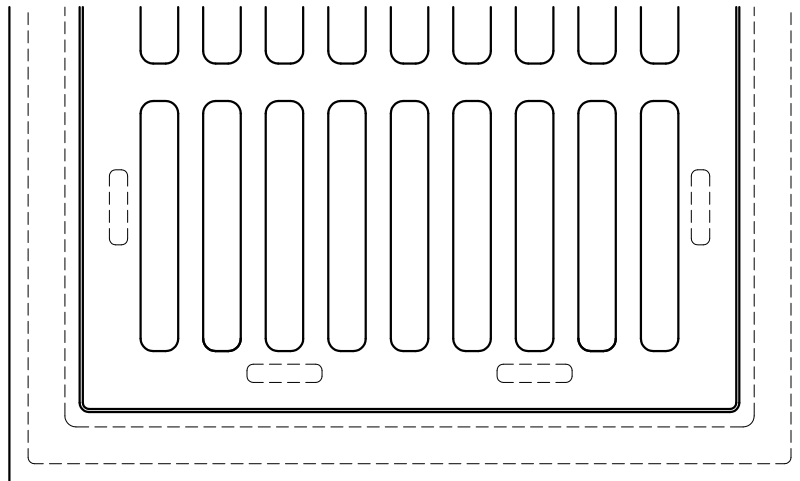

The Wade 2360 Parking deck drains are for installations in precast construction. The support top assembly is precast into the structural slab. The heavy duty top provides maximum strength at the load bearing surface. The drain body is installed by bolting to the top assembly. The drain piping is connected to the body outlet with with any of three connections; No-Hub, Inside Caulk, or Push-On Ty-Seal. The type of connection must be specified upon ordering any Wade Drain. If the Ty-Seal connection is specified, apply Tyler Ty-Seal lubricant to the inside surfaces of the gasket and then firmly push the pipe into the gasket until it contacts the pipe stop in the body. No-Hub outlets should be installed with Tyler or Anaco/Husky couplings and secured with a torque wrench to the manufacturers recommendations. Inside Caulk connections should follow standard industry practices. Care must be taken to protect the top during installation. Use either cardboard, tape or other protective materials.

Note: If the piping is to be connected to a sanitary sewer system, a P-Trap must be installed at the drain outlet.