

PARKING DECK DRAIN



Approval Date

Customer Approval

Job Location

Job Name

Wade Division / Tyler Pipe Assumes No Responsibility For Superseded or Voided Data
 Wade Division / Tyler Pipe Assumes No Responsibility For Superseded or Voided Data
 are Subject to Manufacturers Tolerance and Change Without Notice.

1310-PG

CAST IRON PARKING DECK DRAIN WITH HEAVY DUTY SUPPORT FLANGE, DUCTILE IRON TRACTOR STYLE GRATE, CLAMPING COLLAR AND BOTTOM OUTLET.
 INSTALLATION INSTRUCTIONS

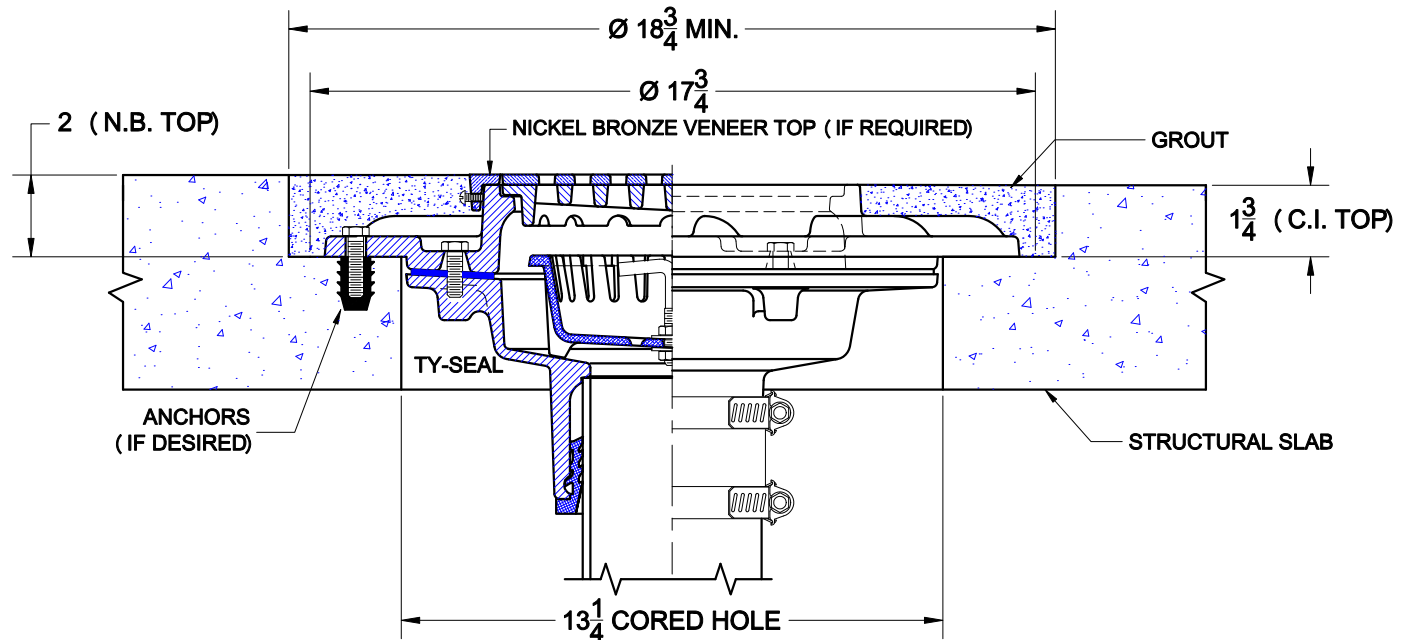
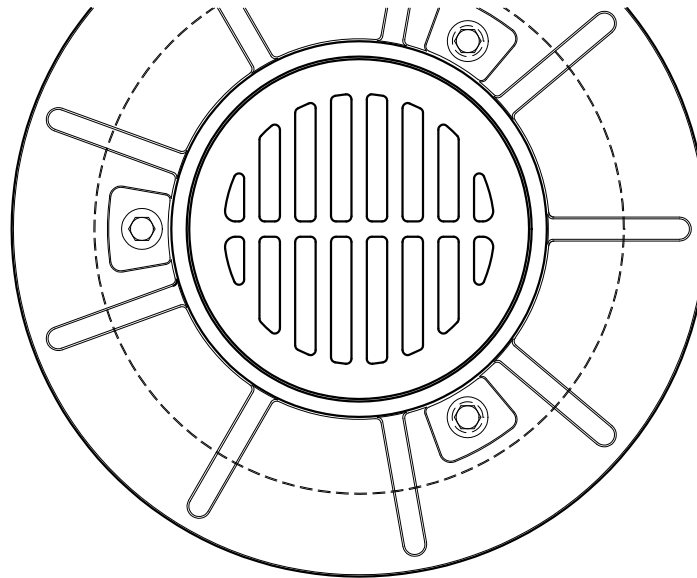

The Wade 1310-PG Parking deck drains are for installations in precast construction. The wide heavy duty support flange allows for shallow core drilling or boxing out. The heavy duty flange provides maximum strength at the load bearing surface. At the predetermined location, the drain is set into the floor recess. If desired, anchors are predrilled and secured to the flange. The surrounding area is finished with the specified grout flush with the top of the drain. The drain piping is connected to the body outlet with any of four connections; Threaded, No-Hub, Inside Caulk, or Push-On Ty-Seal. The type of connection must be specified upon ordering any Wade Drain. If the Ty-Seal connection is specified, apply Tyler Ty-Seal lubricant to the inside surfaces of the gasket and then firmly push the pipe into the gasket until it contacts the pipe stop in the body. No-Hub outlets should be installed with Tyler or Anaco/Husky couplings and secured with a torque wrench to the manufacturers recommendations. Threaded or Inside Caulk connections should follow standard industry practices. Care must be taken to protect the top during installation. Use either cardboard, tape or other protective materials.

Note: If the piping is to be connected to a sanitary sewer system, a P-Trap must be installed at the drain outlet.

AutoCad.dwg