

CLEANOUT FERRULE WITH PLUG

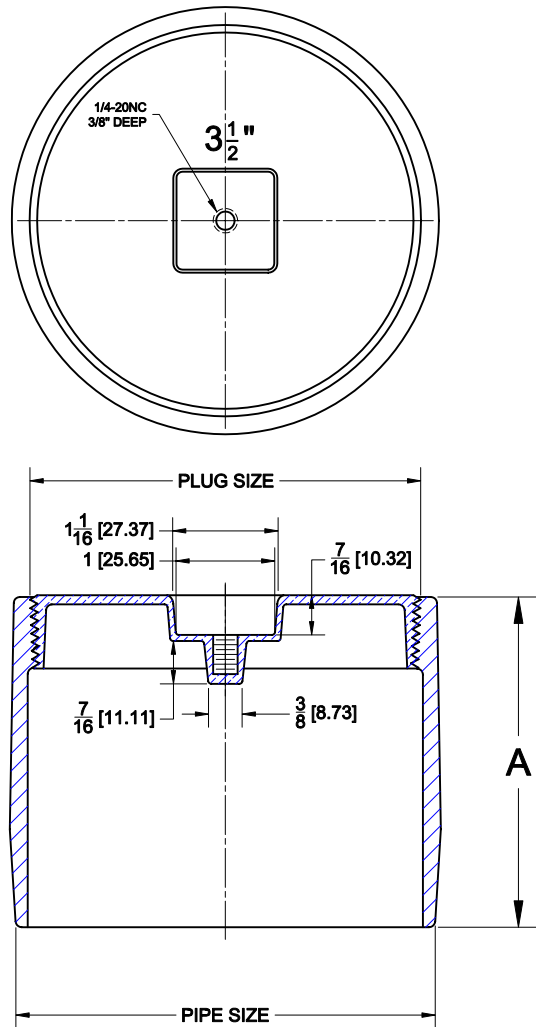

8550-E

CAST IRON CLEANOUT FERRULE WITH NPT THREADED BRASS PLUG WITH COUNTERSUNK HEAD.



PIPE SIZE	PLUG SIZE	A
2 (50)	1 1/2 (38)	2 3/4 (69.8)
3 (75)	2 1/2 (63)	3 (76.2)
4 (100)	3 1/2 (90)	3 1/4 (82.5)
5 (125)	4 (100)	4 3/8 (111.1)
6 (150)	5 (125)	4 1/2 (114.3)
8 (200)	6 (150)	4 5/8 (117.4)

Cat. No.	Pipe Size	Wt. Lbs.
8552-E	2 (50)	1.5
8553-E	3 (75)	2.5
8554-E	4 (100)	4.0
8555-E	5 (125)	6.0
8556-E	6 (150)	9.0
8558-E	8 (200)	10.5

AutoCad.dwg