

SOLIDS INTERCEPTOR

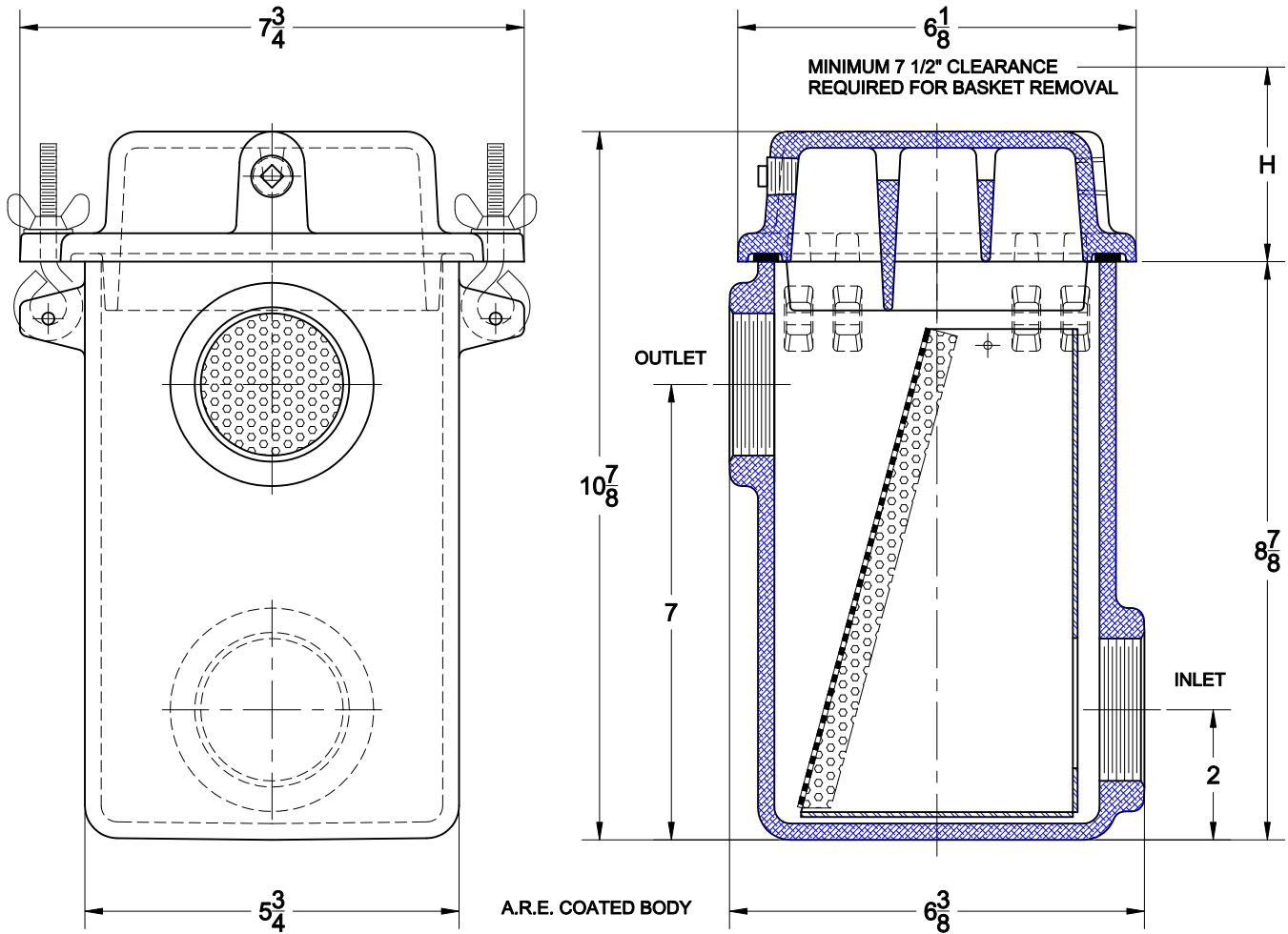

5720

CAST ALUMINUM SOLIDS INTERCEPTOR WITH A.R. PAINT, GASKETED COVER, REMOVABLE SEDIMENT BUCKET WITH S/S PERFORATED SCREEN AND THREADED INLET/OUTLET.



			OPTIONS	
Cat. No.	Pipe Size	Wt. Lbs.	Suffix	Description
<input type="checkbox"/> 5720	2	10.0	<input type="checkbox"/> 63	A.R.E. COATING INSIDE & OUTSIDE
<input type="checkbox"/>			<input type="checkbox"/> 68	STAINLESS STEEL PERFORATED BUCKET

AutoCad.dwg