

DOWNSPOUT NOZZLE

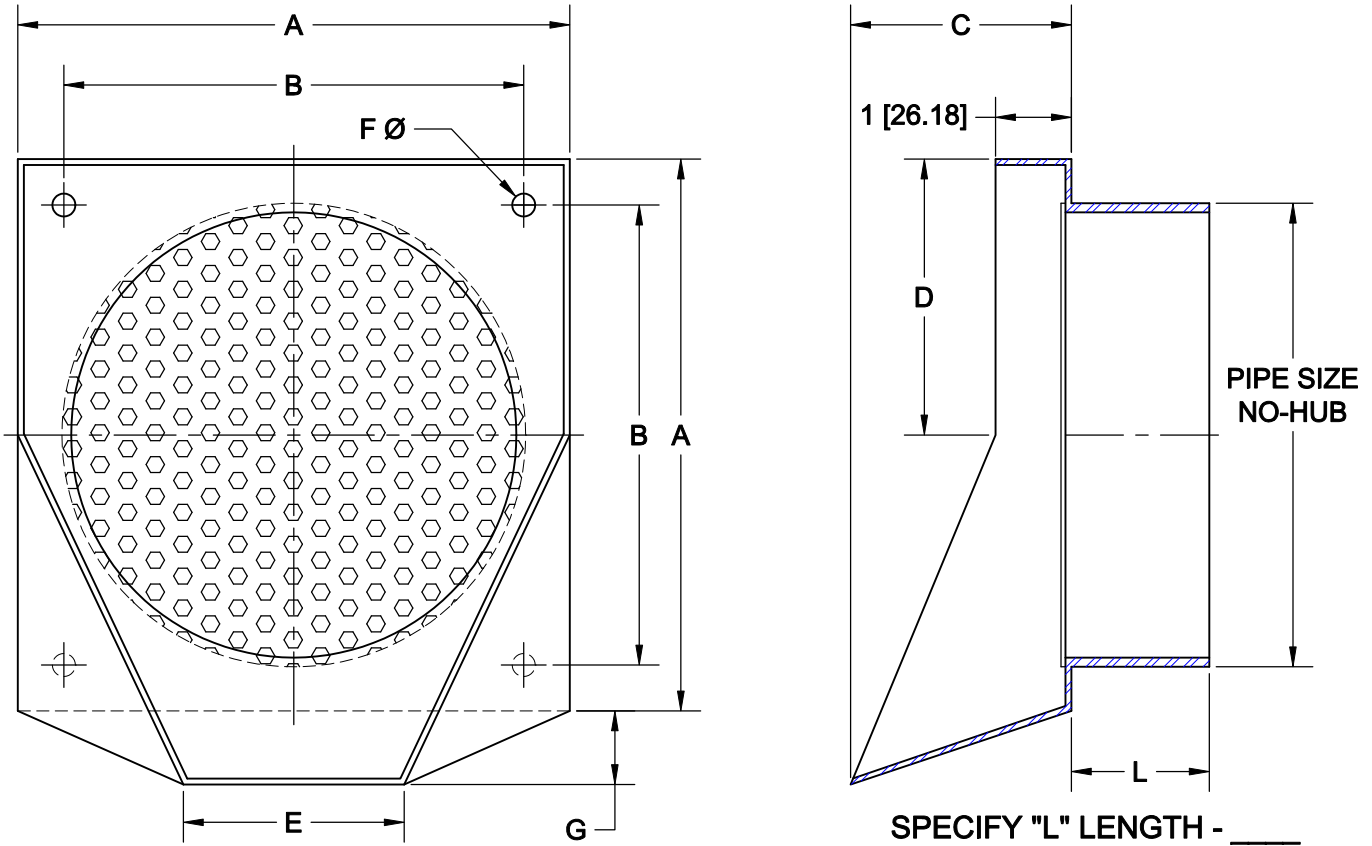

3940-SS-185

304 STAINLESS STEEL DOWNSPOUT NOZZLE WITH NO-HUB OUTLET, ANCHOR SCREW HOLES & PERFORATED BIRD SCREEN (3/16" DIA. PREFORATIONS - STAGGERED CENTERS)



PIPE SIZE	DIMENSIONS (IN/MM)						
	A	B	C	D	E	F	G
3" (75)	4 1/2 (114.3)	3 1/4 (82.5)	3 (76.2)	2 1/4 (57.2)	2 (50.8)	5/16Ø (7.9)	3/4 (19.1)
4" (100)	5 1/2 (139.7)	4 1/4 (107.9)	3 (76.2)	2 3/4 (69.9)	2 (50.8)	5/16Ø (7.9)	1 (25.4)
5" (125)	6 1/2 (165.1)	5 1/4 (133.3)	3 (76.2)	3 1/4 (82.6)	3 (76.2)	5/16Ø (7.9)	1 (25.4)
6" (150)	7 1/2 (190.5)	6 1/4 (158.7)	3 (76.2)	3 3/4 (95.3)	3 (76.2)	5/16Ø (7.9)	1 (25.4)
8" (200)	9 5/8 (244.5)	7 5/8 (193.1)	4 (102.4)	4 7/8 (122.2)	4 (102.4)	5/16Ø (7.9)	1 1/8 (28.9)
10" (250)	13 (329.8)	10 1/4 (260.0)	5 (125.9)	6 3/8 (163.3)	5 (128.0)	7/16Ø (11.1)	1 7/8 (47.4)
12" (300)	14 (355.2)	11 1/4 (285.4)	6 (151.3)	6 7/8 (176.0)	6 (151.3)	7/16Ø (11.1)	1 7/8 (47.4)
15" (380)	18 (455.6)	14 5/8 (370.0)	7 (179.0)	9 (227.8)	9 (227.8)	7/16Ø (11.1)	1 7/8 (47.4)

OPTIONS

Cat. No.	Pipe Size	Wt. Lbs.	Suffix	Description
<input type="checkbox"/> 3943-SS-185	3 (75)	8.0	<input type="checkbox"/> 85	S/S PERFORATED BIRD/RODENT SCREEN
<input type="checkbox"/> 3944-SS-185	4 (100)	9.0	<input type="checkbox"/> 184	OUTLET LENGTH OVER 10" (PER IN)
<input type="checkbox"/> 3945-SS-185	5 (125)	10.0		
<input type="checkbox"/> 3946-SS-185	6 (150)	15.0		
<input type="checkbox"/> 3948-SS-185	8 (200)	17.0		
<input type="checkbox"/> 3940-10-SS-185	10 (250)	18.0		
<input type="checkbox"/> 3940-12-SS-185	12 (300)	20.0		
<input type="checkbox"/> 3940-15-SS-185	15 (380)	22.0		