

EXPANSION JOINT

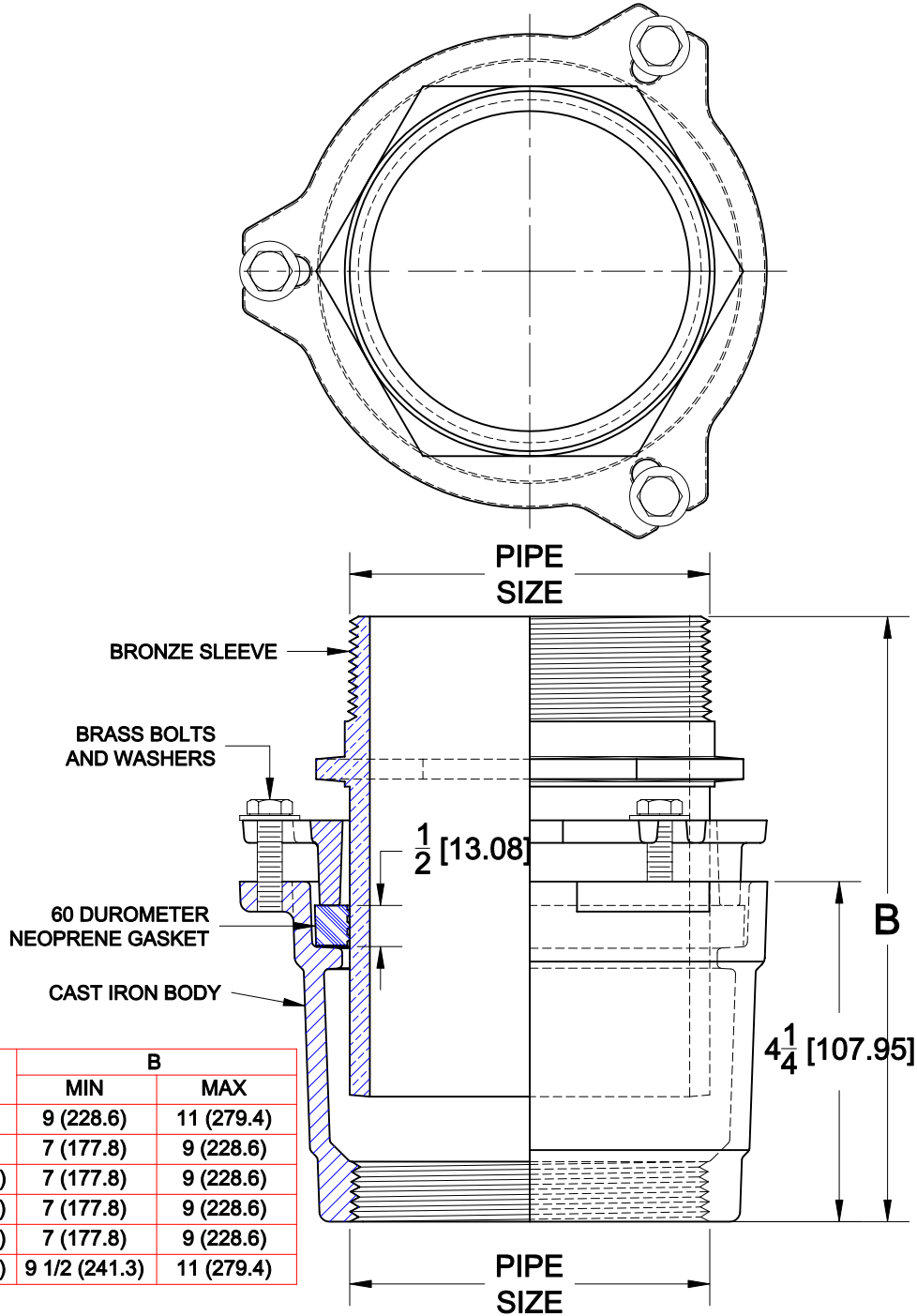

3900

PAINTED CAST IRON EXPANSION JOINT WITH BRONZE SLEEVE, THREADED INLET AND OUTLET, HARDWARE AND NEOPRENE GASKET.



PIPE SIZE	B	
	MIN	MAX
2" (50)	9 (228.6)	11 (279.4)
3" (75)	7 (177.8)	9 (228.6)
4" (100)	7 (177.8)	9 (228.6)
5" (125)	7 (177.8)	9 (228.6)
6" (150)	7 (177.8)	9 (228.6)
8" (200)	9 1/2 (241.3)	11 (279.4)

OPTIONS

Cat. No.	Pipe Size	Wt. Lbs.	Suffix	Description
<input type="checkbox"/> 3902	2 (50)	12.0	<input type="checkbox"/> 39	GALVANIZED IRON PARTS
<input type="checkbox"/> 3903	3 (75)	12.0	<input type="checkbox"/> 176	BRASS HARDWARE
<input type="checkbox"/> 3904	4 (100)	15.0		
<input type="checkbox"/> 3905	5 (125)	19.0		
<input type="checkbox"/> 3906	6 (150)	22.0		
<input type="checkbox"/> 3908	8 (200)	32.0		

AutoCad.dwg