

# DOWNSPOUT COVER



## 3880-SS

STAINLESS STEEL DOWNSPOUT COVER WITH HINGED PERFORATED GRATE AND ROUND FRAME WITH ANCHOR HOLES.

MATERIAL: TYPE 304 STAINLESS STEEL

BODY: 14 GA

HINGED COVER: 1/8"

FLANGE: 1/8"

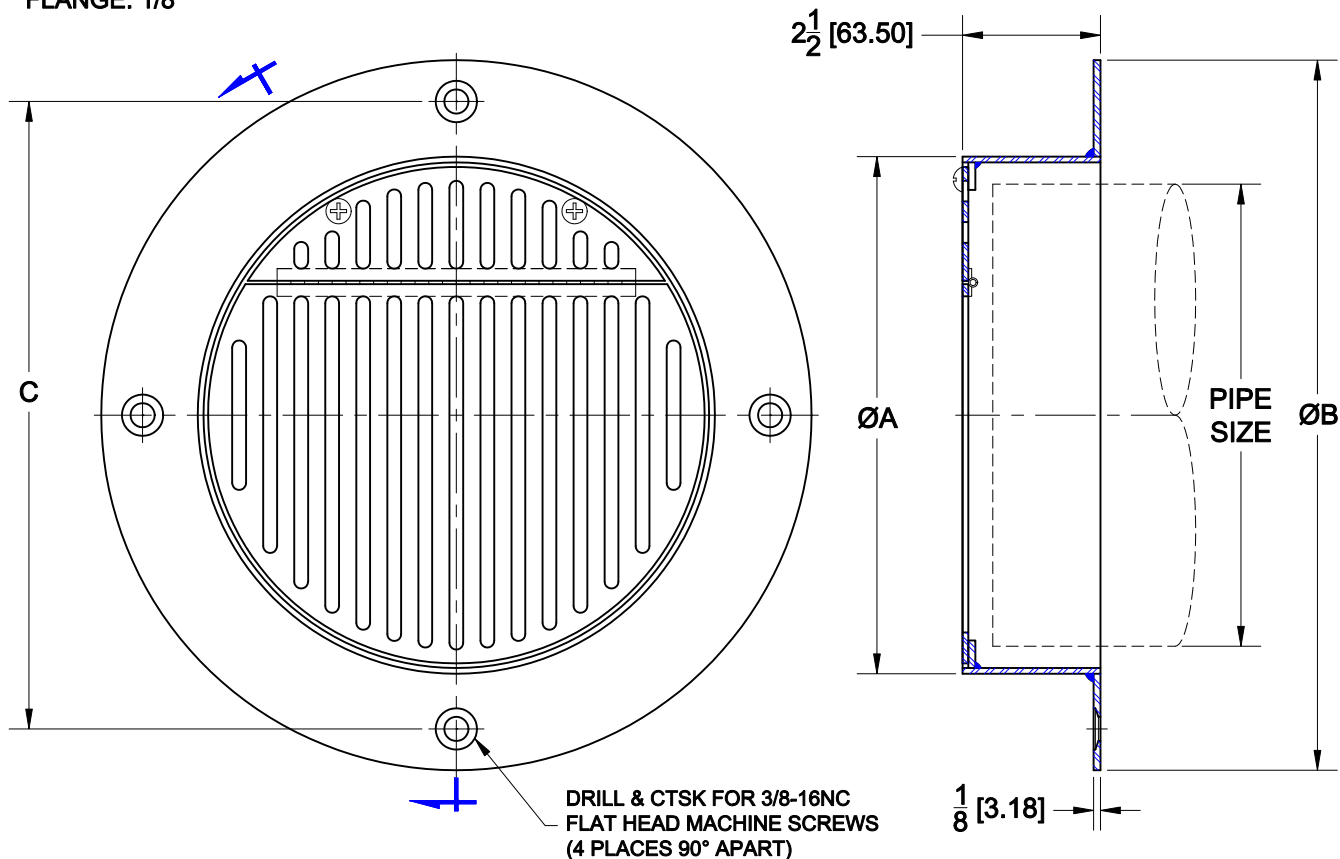

PIPE SIZE	A	B	C
3" (75)	4 1/4 (108)	7 3/4 (197)	6 1/4 (159)
4" (100)	5 1/2 (140)	8 3/4 (222)	7 1/4 (184)
6" (150)	8 1/4 (210)	11 3/4 (298)	10 1/4 (260)
8" (200)	9 3/8 (238)	12 7/8 (327)	11 3/8 (289)
10" (250)	11 1/2 (292)	15 (381)	13 1/2 (343)
12" (300)	13 1/2 (343)	17 (432)	15 1/2 (394)
15" (380)	15 3/4 (400)	19 1/4 (489)	17 3/4 (451)

### OPTIONS

Cat. No.	Pipe Size	Wt. Lbs.
<input type="checkbox"/> 3880-3SS	3 (75)	4.5
<input type="checkbox"/> 3880-4SS	4 (100)	5.5
<input type="checkbox"/> 3880-6SS	6 (150)	6.0
<input type="checkbox"/> 3880-8SS	8 (200)	9.0
<input type="checkbox"/> 3880-10SS	10 (250)	12.5
<input type="checkbox"/> 3880-12SS	12 (300)	14.0
<input type="checkbox"/> 3880-15SS	15 (380)	17.0

Suffix	Description
<input type="checkbox"/> 179	SECURITY SCREWS
<input type="checkbox"/> XT	FRAME 5" DEEP INSTEAD OF 2-1/2"

### INSTALLATION

1. SLEEVE STRUCTURAL WALL TO RECEIVE PIPE O.D.
2. SEAL SPACE BETWEEN WALL & PIPING
3. SECURELY ANCHOR UNIT TO STRUCTURAL WALL W/ 4 ANCHORS
4. PIPING MUST BE ANCHORED PROPERLY TO PREVENT THRUST

AutoCad.dwg