

# Promenade Deck Drain

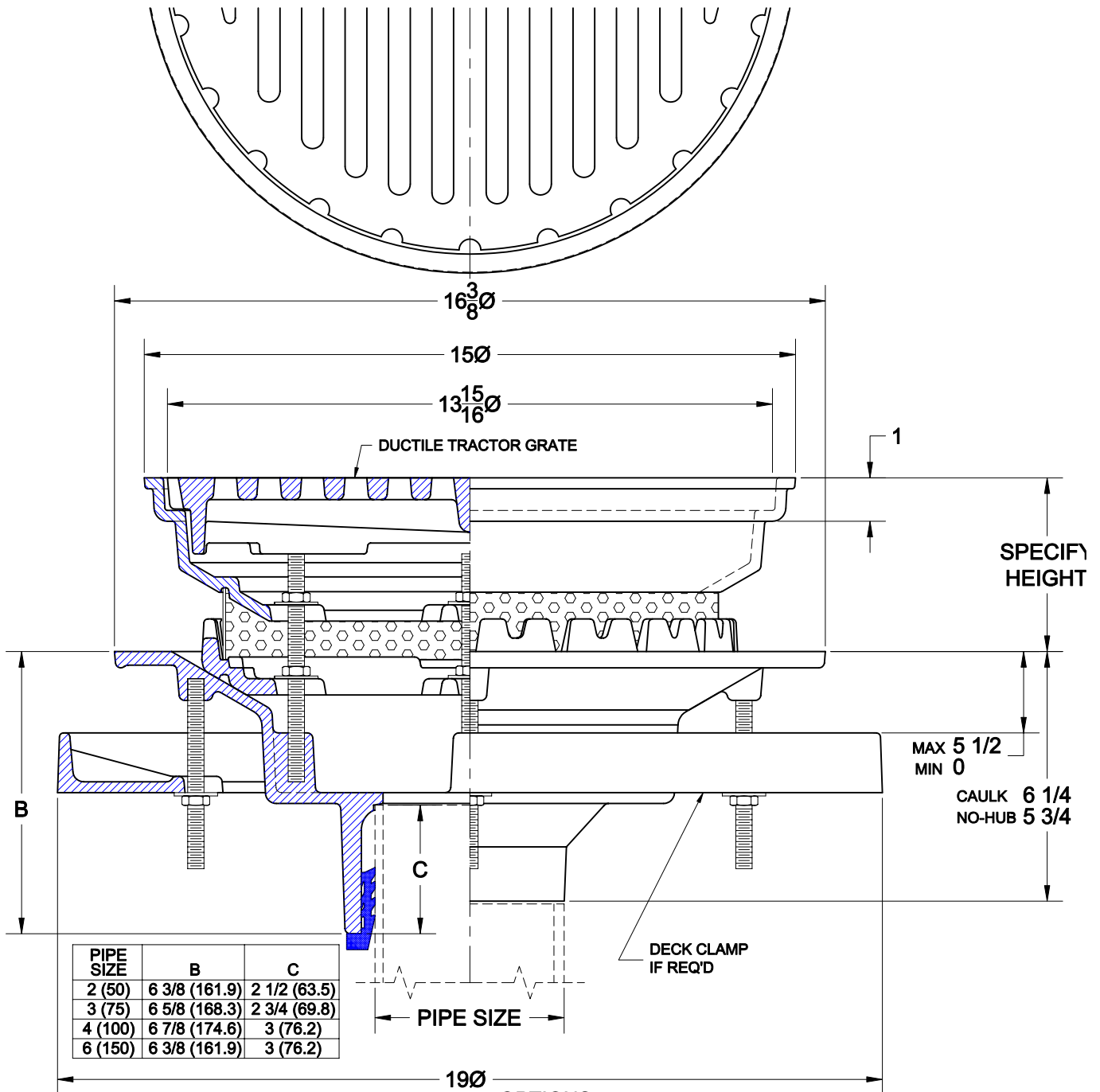

## 3400-DFS

Cast iron deck drain with flashing ring, round promenade top, ductile iron tractor grate, stainless steel perforated extension and bottom outlet.



### OPTIONS

Cat. No.	Pipe Size	Wt. Lbs.	Suffix	Description
<input type="checkbox"/> 3402-DFS	2 (50)	70.0	<input type="checkbox"/> 1	Nickel Bronze Veneer Top
<input type="checkbox"/> 3403-DFS	3 (75)	70.0	<input type="checkbox"/> 5	Vandal Proof
<input type="checkbox"/> 3404-DFS	4 (100)	70.0	<input type="checkbox"/> 52	Bearing Pan (Sump Receiver)
<input type="checkbox"/> 3405-DFS	5 (125)	70.0	<input type="checkbox"/> 53	Underdeck Clamp
<input type="checkbox"/> 3406-DFS	6 (150)	70.0		
<input type="checkbox"/> 3408-DFS	8 (200)	72.0		

### OUTLETS

<input type="checkbox"/> NH	NO-HUB	<input type="checkbox"/> TY	TY-SEAL	<input type="checkbox"/> IC	INSIDE CAULK	<input type="checkbox"/> IPS	THREADED
-----------------------------	--------	-----------------------------	---------	-----------------------------	--------------	------------------------------	----------