

# CLOSET CARRIERS



## 340-HD SERIES

NO-HUB ADJUSTABLE VERTICAL WATER CLOSET CARRIER WITH 4" NO-HUB CONNECTIONS, 2" NO-HUB VENT CONNECTION, UNIVERSAL FLOOR MOUNT FOOT SUPPORTS, REAR ANCHOR SUPPORT (SINGLE CARRIERS), ABS PLASTIC CLOSET COUPLING W/ O-RING SEAL & INTERNAL WRENCH GROOVES, 5/8" HEAVY DUTY SUPPORT HARDWARE, NEOPRENE BOWL GASKET, INTEGRAL TEST CAP, ADJUSTABLE GASKETED FACE PLATE W/ REMOVABLE LUGS AND PLASTIC STUD PROTECTORS.

THIS SYSTEM COMPLIES & EXCEEDS ALL REQUIREMENTS OF ASME A112.6.1M (UP TO 500 LBS)

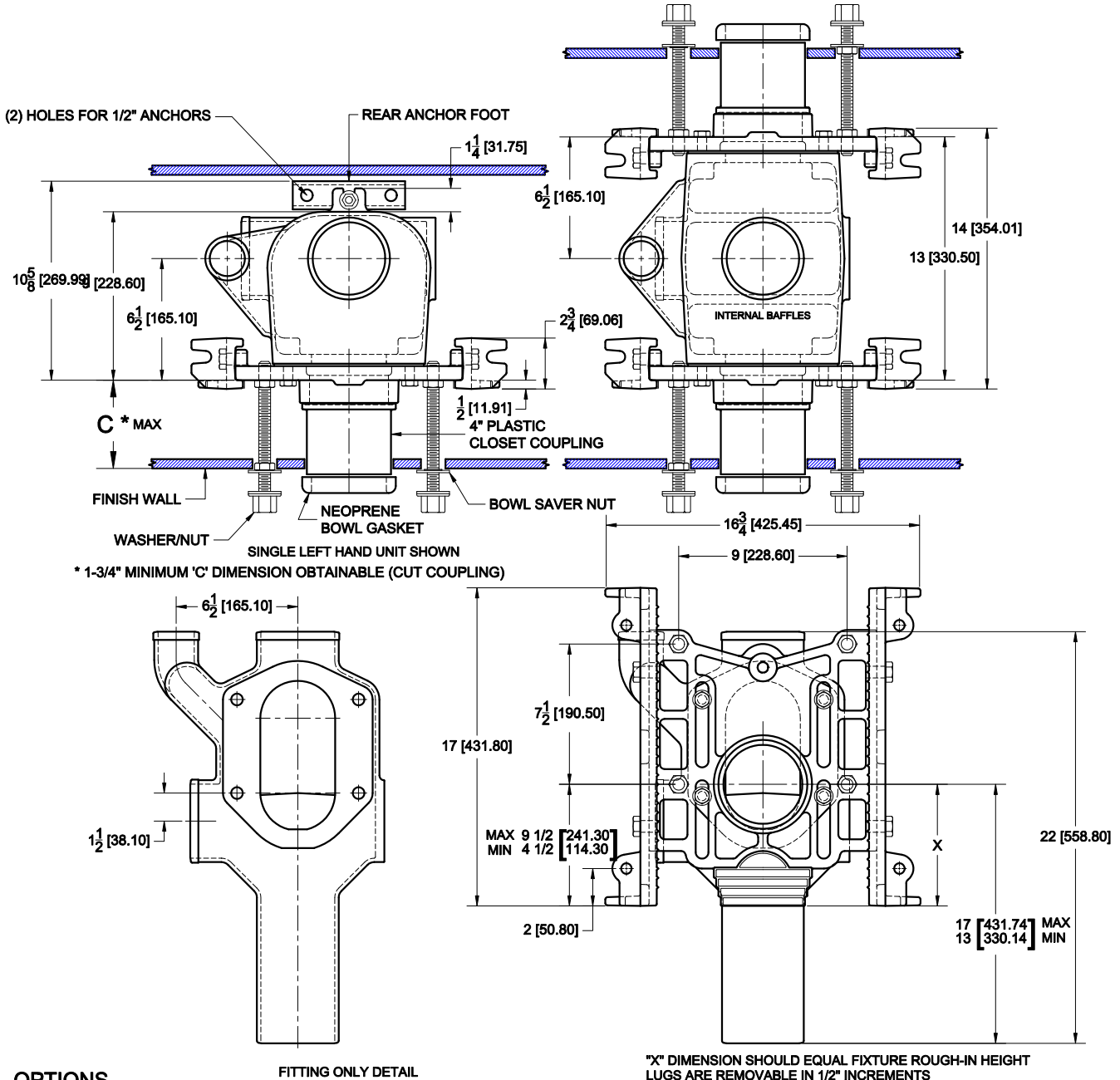

### OPTIONS

Suffix	Description	CAT.NO.	WT.LB.
C7	COUPLING PACKAGE (6" MAX "C" DIMENSION)	340-NL-HD	95.0
C11	COUPLING PACKAGE (10" MAX "C" DIMENSION)	340-NR-HD	95.0
C14	COUPLING PACKAGE (13" MAX "C" DIMENSION)	340-ND-HD	115.0
C24	COUPLING PACKAGE (23" MAX "C" DIMENSION)		
AM4	ROD SUPPORT FEET (REQUIRED FOR "C" DIMENSION OVER 7")		

AutoCad.dwg