

# Small Roof Drain

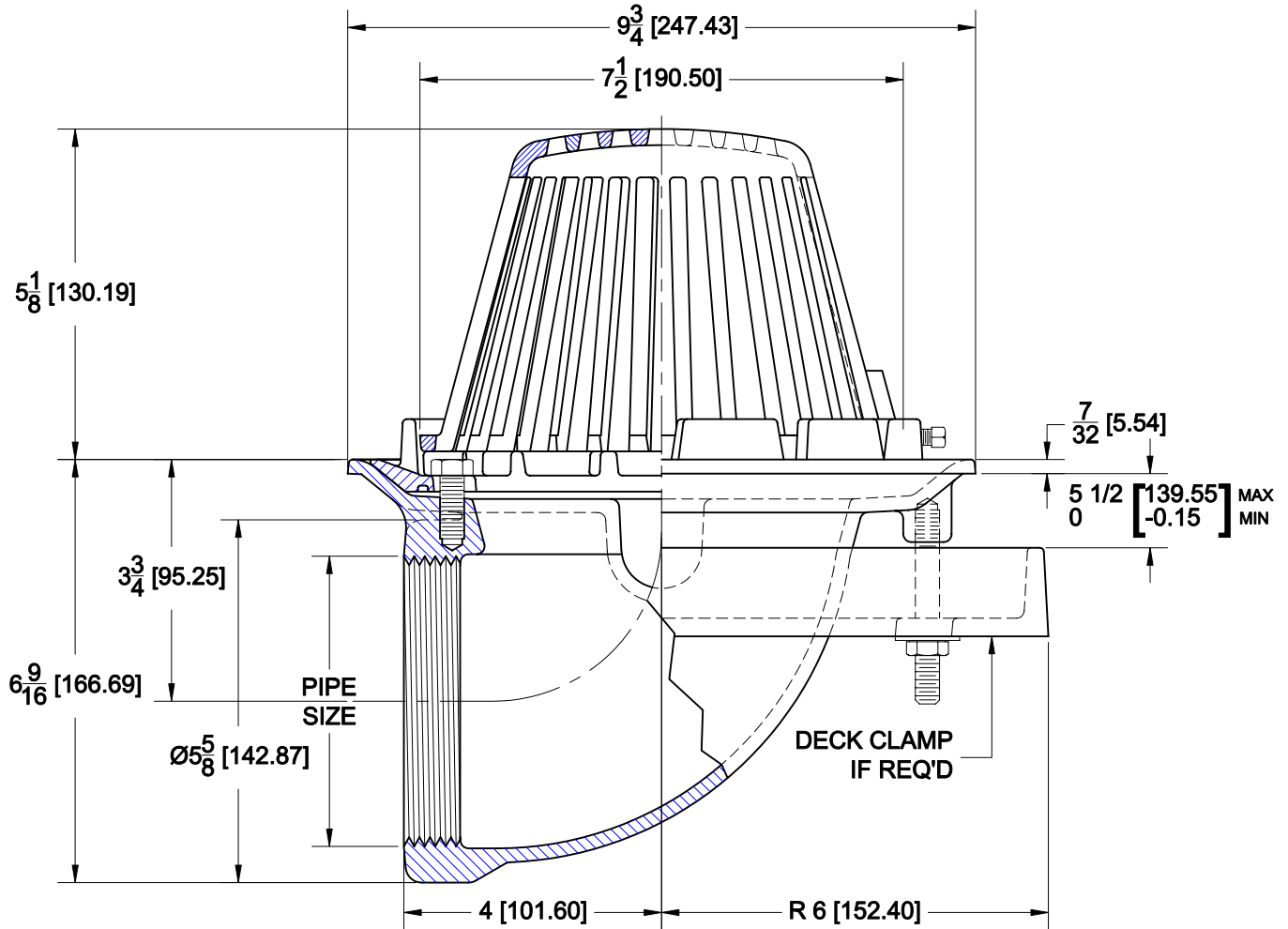

3210

Cast iron roof drain with flashing clamp integral with gravel stop, cast iron beehive dome strainer and threaded side outlet.



## VARIATIONS

Suffix	Description
DF	Extension Flange (2" High)
DFS	Perforated Extension (2",3",4")
D	Dam (2" High)

## OPTIONS

Cat. No.	Pipe Size	Wt. Lbs.	Suffix	Description
3212	2 (50)	19.0	5	Vandal Proof
3213	3 (75)	19.0	39	Galvanized
3214	4 (100)	19.0	52	Bearing Pan
			53	Deck Clamp
			179	Security Screws