

# Small Roof Drain

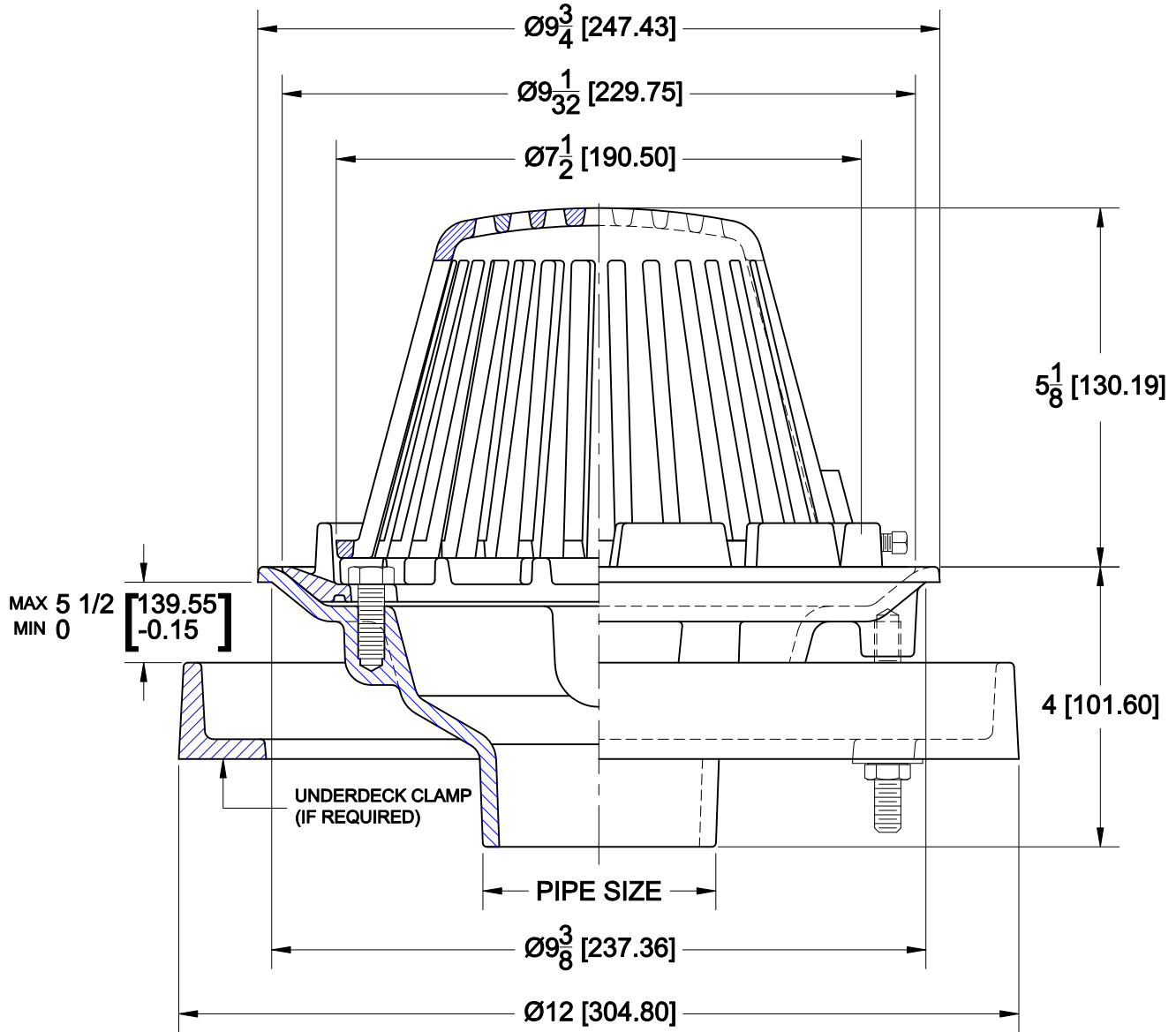

## 3200

Cast iron roof drain with flashing clamp integral with gravel stop, cast iron beehive dome strainer and No-Hub bottom outlet.



### OPTIONS

Cat. No.	Pipe Size	Wt. Lbs.	Suffix	Description
<input type="checkbox"/> 3202	2 (50)	19.0	<input type="checkbox"/> 5	Vandal Proof
<input type="checkbox"/> 3203	3 (75)	19.0	<input type="checkbox"/> 39	Galvanized
<input type="checkbox"/> 3204	4 (100)	19.0	<input type="checkbox"/> 52	Bearing Pan
<input type="checkbox"/> 3206	6 (150)	19.0	<input type="checkbox"/> 53	Deck Clamp
			<input type="checkbox"/> 179	Security Screws (Pin Allen)
			<input type="checkbox"/> 230	Security Screws (Pin Torx)

### VARIATIONS

Suffix	Description
<input type="checkbox"/> DF	Extension Flange (2" High)
<input type="checkbox"/> DFS	Perforated Extension (2",3",4")
<input type="checkbox"/> D	Dam (2" High)

AutoCad.dwg