

SMALL ROOF RECEPTOR DRAIN

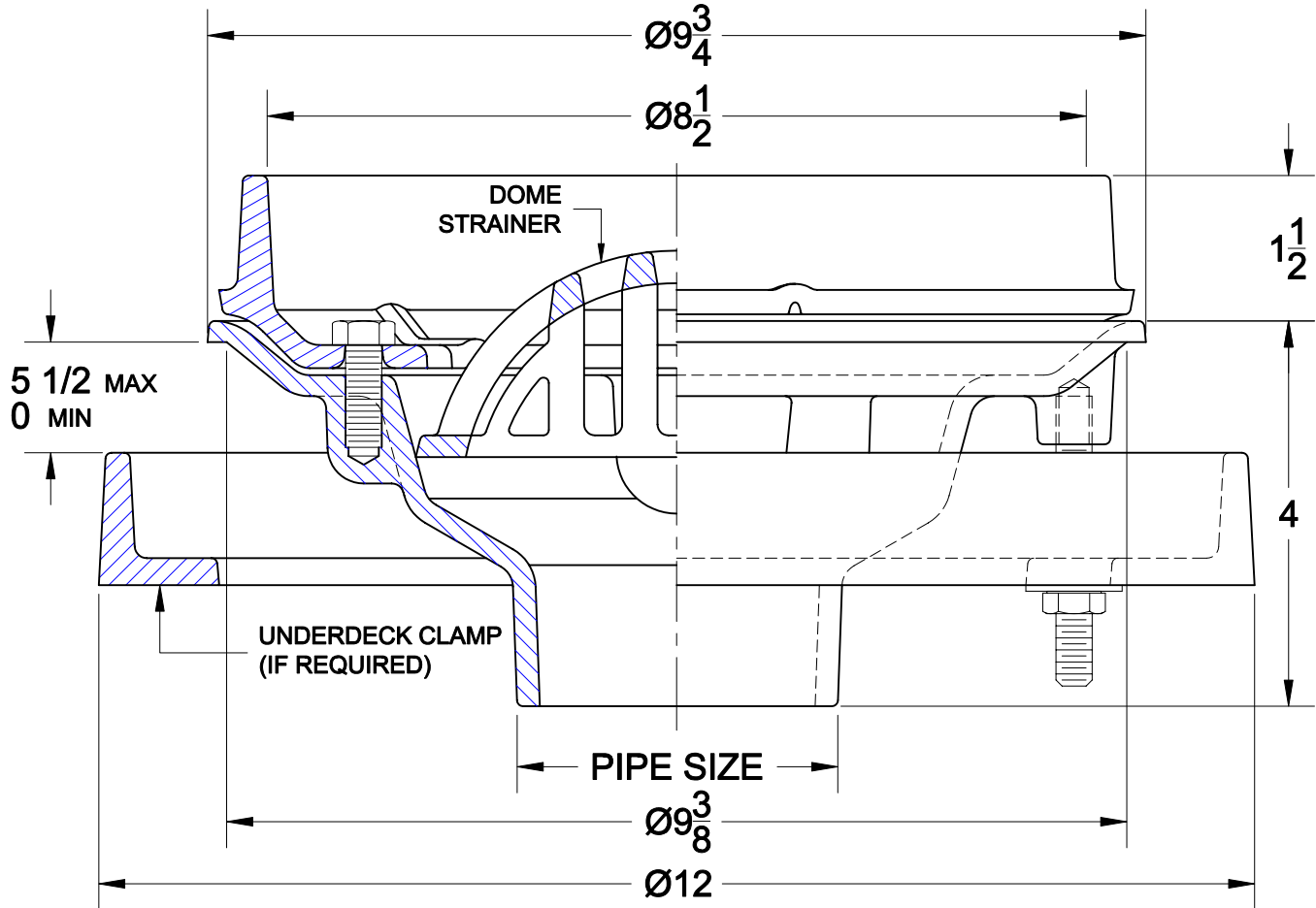

3200-RS

CAST IRON ROOF RECEPTOR DRAIN WITH FLANGE, FLASHING CLAMP INTEGRAL WITH SUMP RECEPTOR, DOME STRAINER AND BOTTOM OUTLET.



VARIATIONS

Cat. No.	Pipe Size	Wt. Lbs.	Suffix	Description
<input type="checkbox"/> 3202-RS	2	19.0	<input type="checkbox"/> DF	EXTENSION FLANGE (2" HIGH)
<input type="checkbox"/> 3203-RS	3	19.0	<input type="checkbox"/> DFS	PERFORATED S/S EXTENSION (2",3",4")
<input type="checkbox"/> 3204-RS	4	19.0		

OPTIONS

Suffix	Description
<input type="checkbox"/> 39	GALVANIZED IRON PARTS
<input type="checkbox"/> 52	BEARING PAN (SUMP RECEIVER)
<input type="checkbox"/> 53	DECK CLAMP

AutoCad.dwg