

# FLOOR CLEANOUT

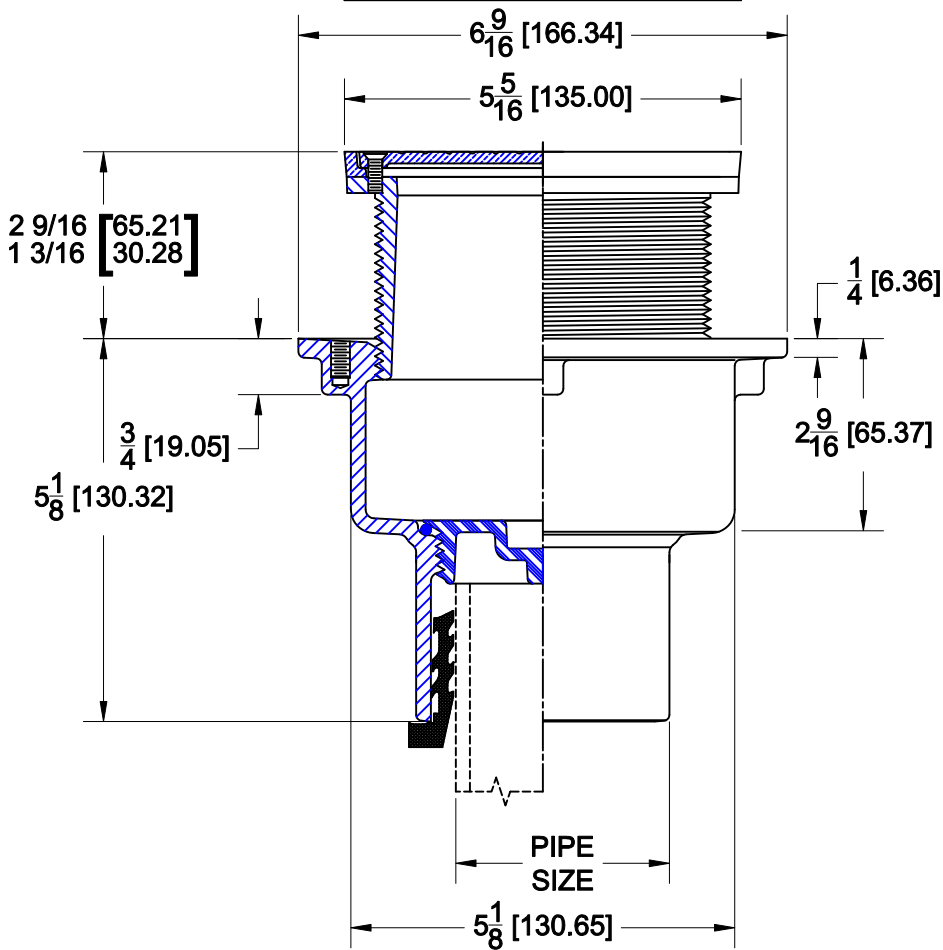

Approval Date: \_\_\_\_\_  
 Customer Approval: \_\_\_\_\_  
 Job Location: \_\_\_\_\_  
 Job Name: \_\_\_\_\_

8000-S  
 PAINTED CAST IRON FLOOR CLEANOUT WITH ADJUSTABLE SQUARE SATIN NICKEL BRONZE TOP, SCORIATED COVER, GASKETED PLUG AND BOTTOM OUTLET

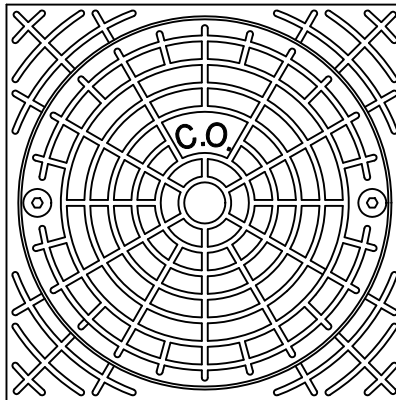

ANSI LOAD RATING - LD LIGHT DUTY (UNDER 2,000 LBS.)

Cat. No.	Pipe Size	Wt. Lbs.	OPTIONS	
			Suffix	Description
<input type="checkbox"/> 8002-S	2 (50)	6.0	<input type="checkbox"/> 39	GALVANIZED IRON PARTS
<input type="checkbox"/> 8003-S	3 (75)	6.4	<input type="checkbox"/> 118	BRONZE GASKETED PLUG
<input type="checkbox"/> 8004-S	4 (100)	7.0	<input type="checkbox"/> 179	SECURITY SCREWS
			<input type="checkbox"/> CM	CARPET MARKER
<input type="checkbox"/> TY	TY-SEAL		<input type="checkbox"/> NH	NO-HUB

AutoCad.dwg

7-1-13

WADE • 11910 CR 492 • Tyler, TX 75706 • PH (903)882-5511 • FAX (888)879-9233  
 WADE Canada • 6200 Rue Principale • Ste-Croix Quebec GOS 2HO • PH (800)463-3480 Ext. 2227 • FAX (888)879-9233

A-80177