

# WATER SAVER TRAP PRIMER



2400-M

AUTOMATIC TRAP SEAL PRIMER WITH CAST BRONZE P-TRAP BODY, 1-1/2" O.D. SPIGOT OUTLET, CHROME PLATED FINISH, S/S BRAIDED PRIMER TUBE, COMPRESSION TUBE FITTINGS AND SLIP JOINT INLET.

1-1/4" & 1-1/2" SLIP JOINT NUTS AND SEALS ARE PROVIDED TO ACCOMODATE FIXTURE TAILPIECES.

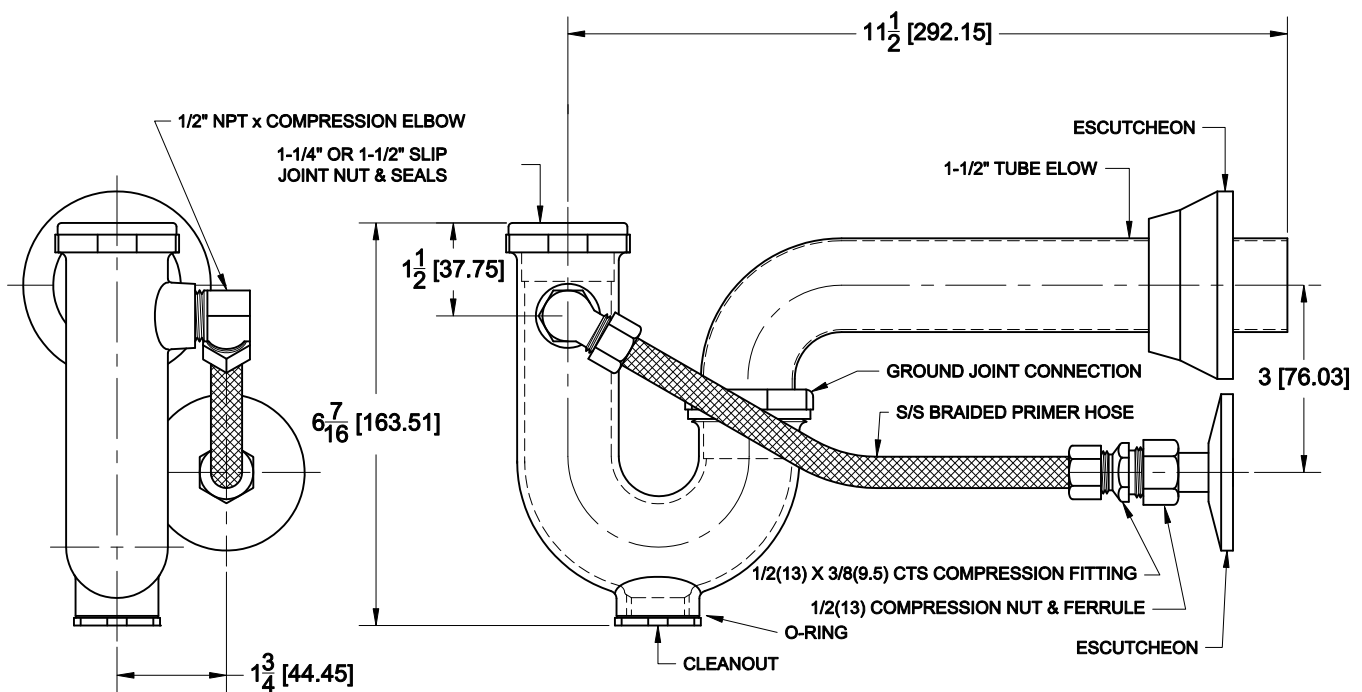

 POLISHED CHROME PLATED

**FUNCTION:** The water saver trap primer utilizes the temporary "head" of water in the p-trap which occurs during use of lavatories, sinks and drinking fountains to overflow through the primer tube connection and thus gravity flow through piping under the floor to a floor drain trap primer connection, maintaining the trap seal.