

# SQUARE FLOOR DRAINS



2320

CAST IRON SQUARE FLOOR DRAIN WITH DUCTILE IRON TRACTOR GRATE, CLAMP DEVICE, 1/2" TRAP PRIMER CONNECTION AND NO-HUB BOTTOM OUTLET.

ANSI LOAD RATING - SD (SPECIAL DUTY) OVER 10,000 LBS  
GRATE FREE AREA = 52.4 SQ.IN.

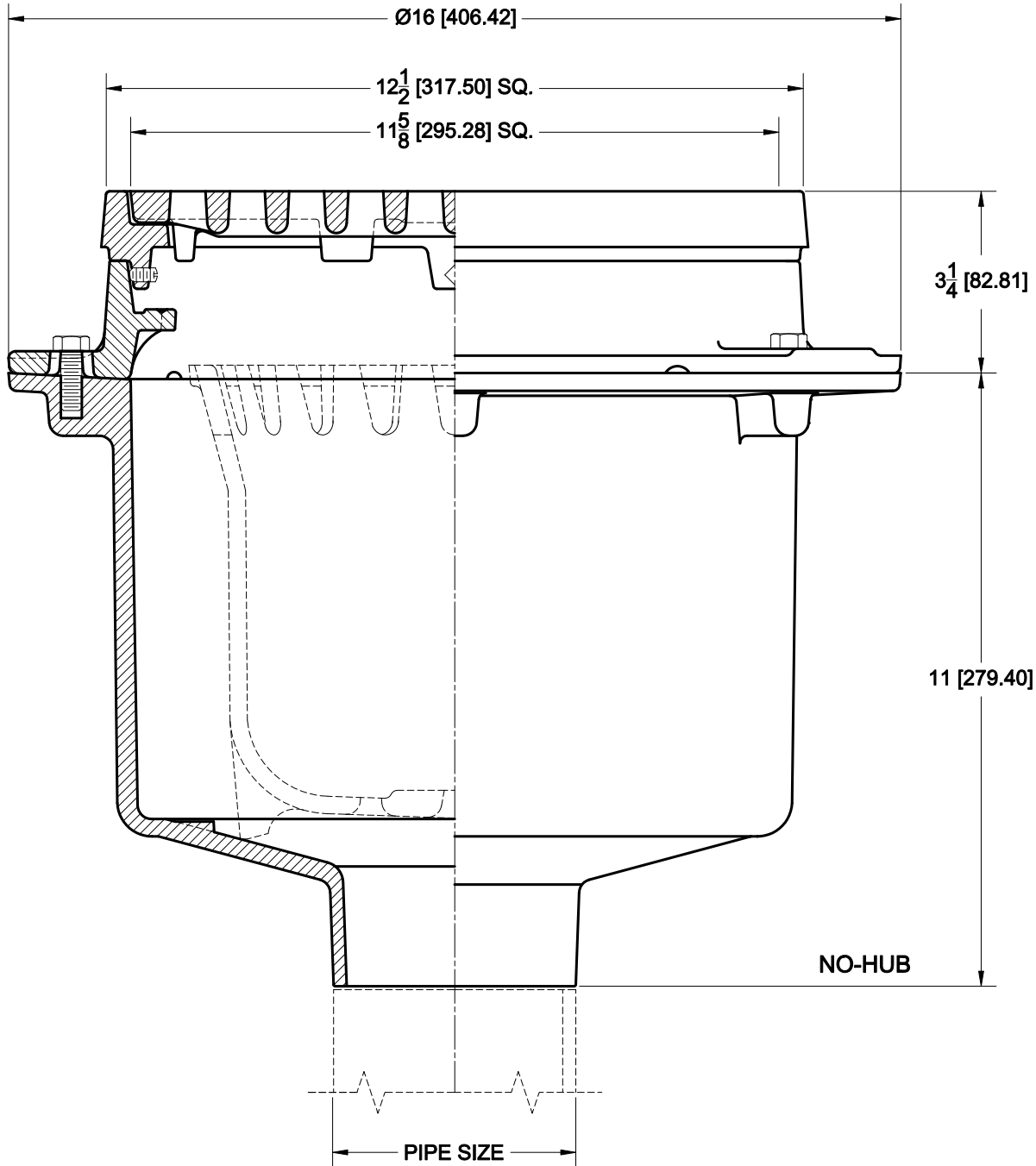

## OPTIONS

Cat. No.	Pipe Size	Wt. Lbs.	Suffix	Description
<input type="checkbox"/> 2323	3 (75)	92.0	<input type="checkbox"/> 1	SATIN FINISH NICKEL BRONZE VENEER TOP
<input type="checkbox"/> 2324	4 (100)	92.0	<input type="checkbox"/> 5	VANDAL PROOF
<input type="checkbox"/> 2326	5 (125)	92.0	<input type="checkbox"/> 27	SEDIMENT BUCKET (ALUMINUM)
<input type="checkbox"/> 2328	8 (200)	93.0	<input type="checkbox"/> 31	BACKWATER VALVE (2,3,4" ONLY)
			<input type="checkbox"/> 39	GALVANIZED IRON PARTS

AutoCad.dwg