

SERVICE SINK CARRIER



Approval Date

Customer Approval

Job Location

Job Name

Dimensional Data (Inches/mm) are Subject to Manufacturers Tolerance and Change Without Notice. Wade Division / Tyler Pipe Assumes No Responsibility For Superseded or Voided Data

620-011

HANGER PLATE CARRIER WITH PIPE UPRIGHTS, WELDED BASE FEET, A.R.E. EXPOSED ARMS AND SUPPORT HARDWARE.

FIXTURE

Manufacturer Wade

Name _____ No. 14

Style Service Sink 18

MS2218DB

MS2218B

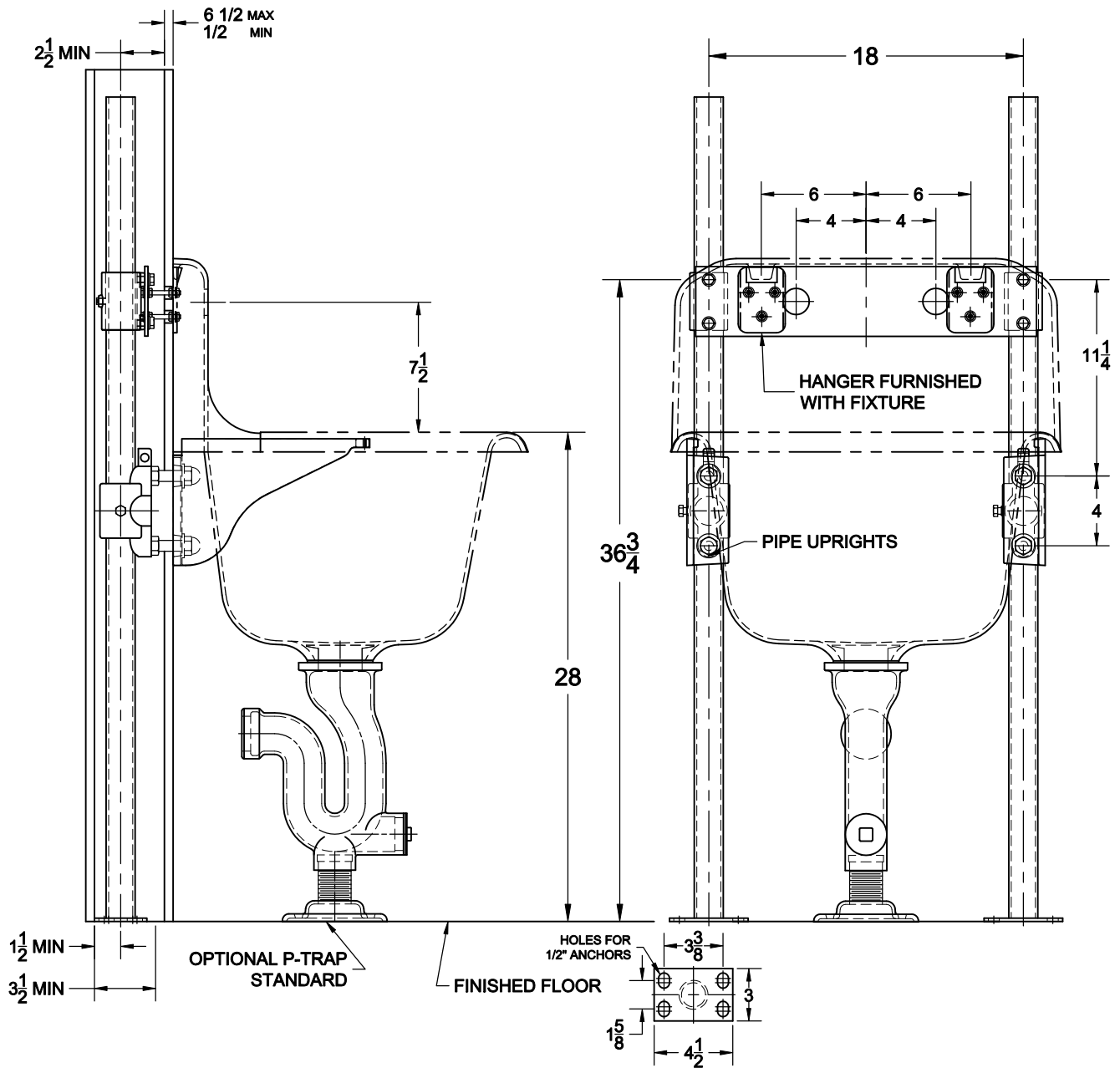

OPTIONS

| Cat. No. | Type | Wt. Lbs. | Suffix | Description |
|----------|------|----------|--------|-----------------|
| 620-011 | SGL | 59.0 | M36 | SQUARE UPRIGHTS |

NOTE: CONTRACTOR MUST VERIFY DIMENSIONS WITH FIXTURE MANUFACTURER ROUGH-IN DATA TYLER PIPE / WADE DIVISION ACCEPTS NO RESPONSIBILITY FOR ANY INACCURACIES IN DRAWING

AutoCad.dwg