

URINAL CARRIER



623-AM11-M22

Trough Urinal carrier with pipe uprights, welded base feet and fixture support hardware.

FIXTURE

Manufacturer ACORN

Name DURA-WARE No. 2173

Style URINAL

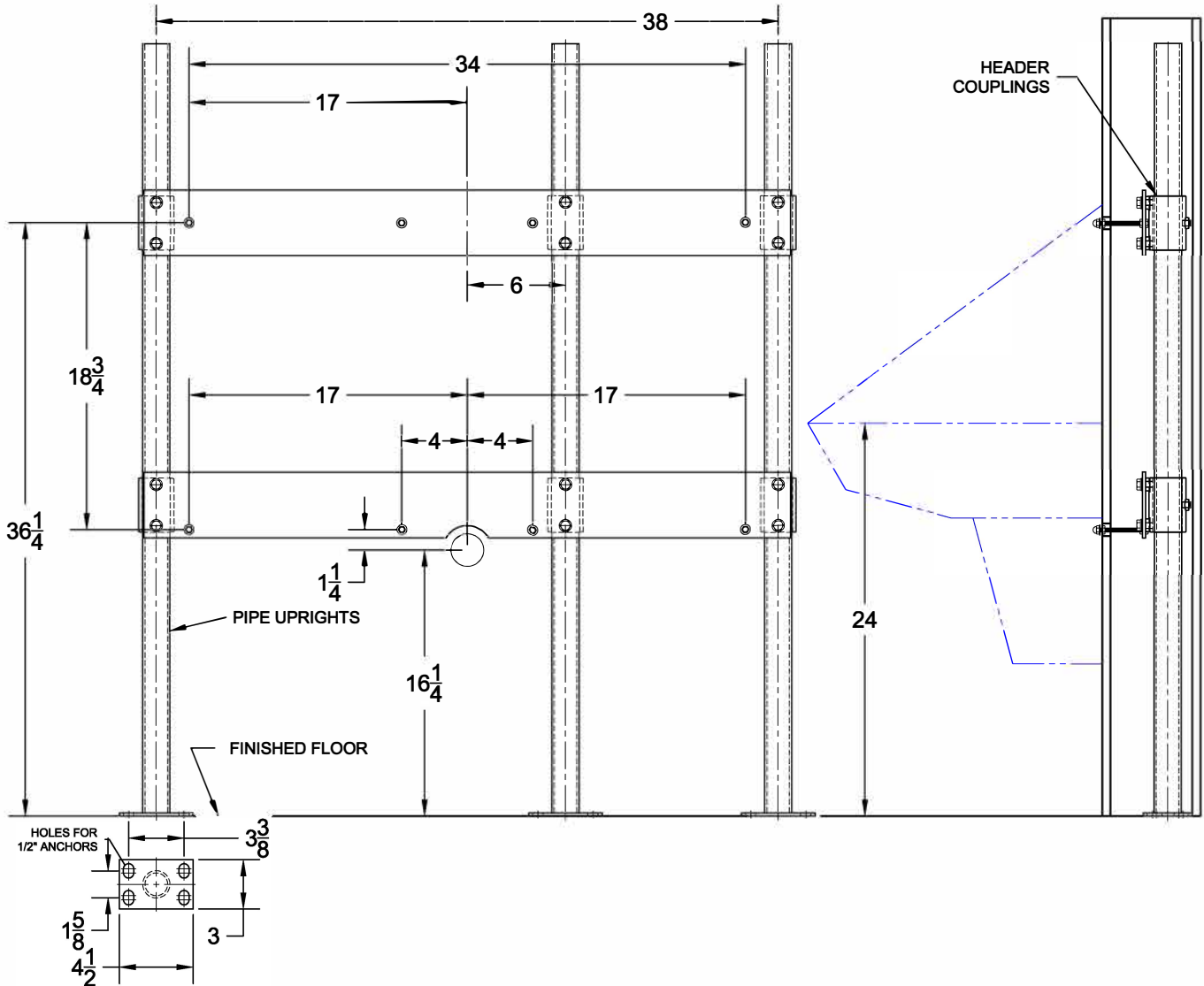

Cat. No.	Type	Wt. Lbs.
<input type="checkbox"/> 623-AM11-M22	Single	45.0

OPTIONS	
Suffix	Description
<input type="checkbox"/> M36	Rectangular Steel Uprights
<input type="checkbox"/> M3	Vandal Proof Cap Nuts

AutoCad.dwg