

SERVICE SINK CARRIER



620-011

HANGER PLATE CARRIER WITH PIPE UPRIGHTS,
WELDED BASE FEET, A.R.E. EXPOSED ARMS
AND SUPPORT HARDWARE.

FIXTURE

Manufacturer Kohler

Name Bannon No. K-6714

Style Service Sink K-6718

Approval
Date

Customer
Approval

Job
Location

Job
Name

Dimensional Data (Inches/mm) are Subject to Manufacturers Tolerance and Change Without Notice.

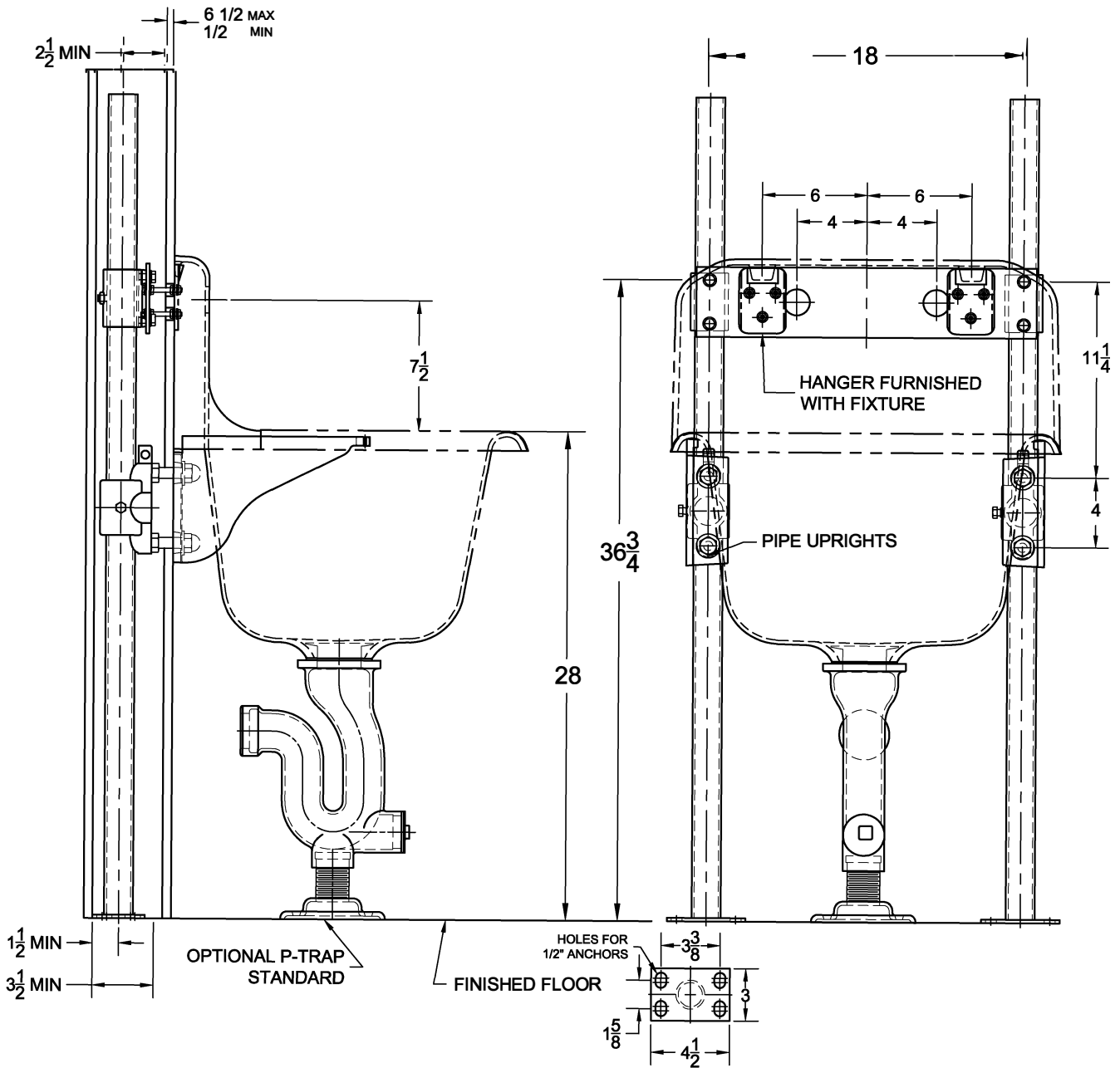

OPTIONS

Cat. No.	Type	Wt. Lbs.	Suffix	Description
<input type="checkbox"/> 620-011	SGL	59.0	<input type="checkbox"/> M36	SQUARE UPRIGHTS

NOTE: CONTRACTOR MUST VERIFY DIMENSIONS WITH FIXTURE MANUFACTURER ROUGH-IN DATA
WADE DRAINS ACCEPTS NO RESPONSIBILITY FOR ANY INACCURACIES IN DRAWING

AutoCad_{dwg}