

SERVICE SINK CARRIER



620-011

HANGER PLATE CARRIER WITH PIPE UPRIGHTS,
WELDED BASE FEET, A.R.E. EXPOSED ARMS
AND SUPPORT HARDWARE.

FIXTURE

Manufacturer American Standard

Name Akron No. 7695.000

Style Service Sink 7695.008

Approval
Date

Customer
Approval

Job
Location

Job
Name

Dimensional Data (Inches/mm) are Subject to Manufacturers Tolerance and Change Without Notice.

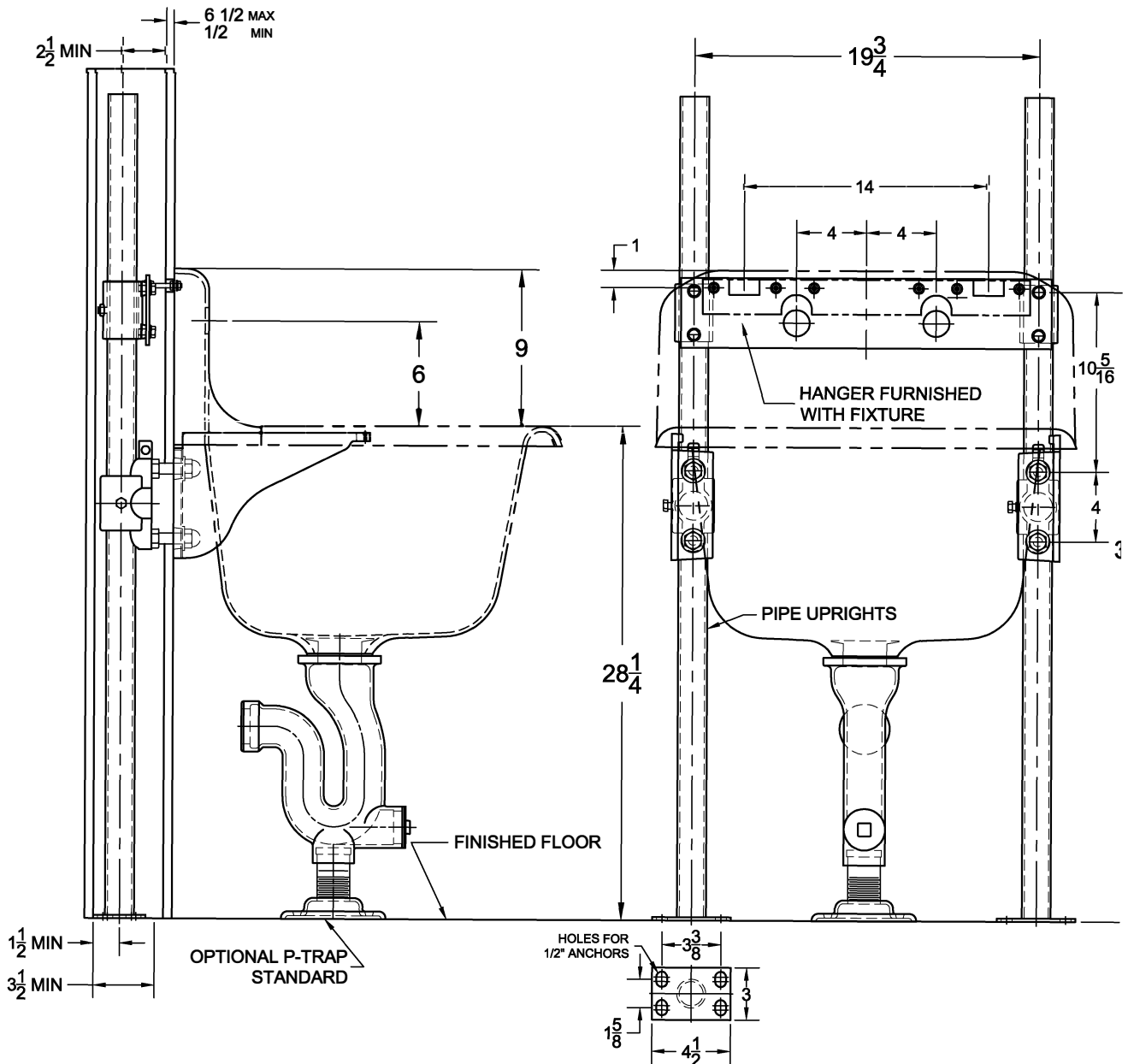

OPTIONS

Cat. No.	Type	Wt. Lbs.	Suffix	Description
620-011	SGL	59.0	M36	SQUARE UPRIGHTS

NOTE: CONTRACTOR MUST VERIFY DIMENSIONS WITH FIXTURE MANUFACTURER ROUGH-IN DATA
TYLER PIPE / WADE DIVISION ACCEPTS NO RESPONSIBILITY FOR ANY INACCURACIES IN DRAWING