

LAVATORY CARRIER



401-M29

HANGER PLATE CARRIER WITH PIPE UPRIGHTS,
WELDED BASE FEET & HARDWARE.

FIXTURE

Manufacturer Kohler

Name Pinoir No. K-2015

Style Lavatory

Approval
Date

Customer
Approval

Job
Location

Job
Name

Dimensional Data (Inches/mm) are Subject to Manufacturers Tolerance and Change Without Notice.

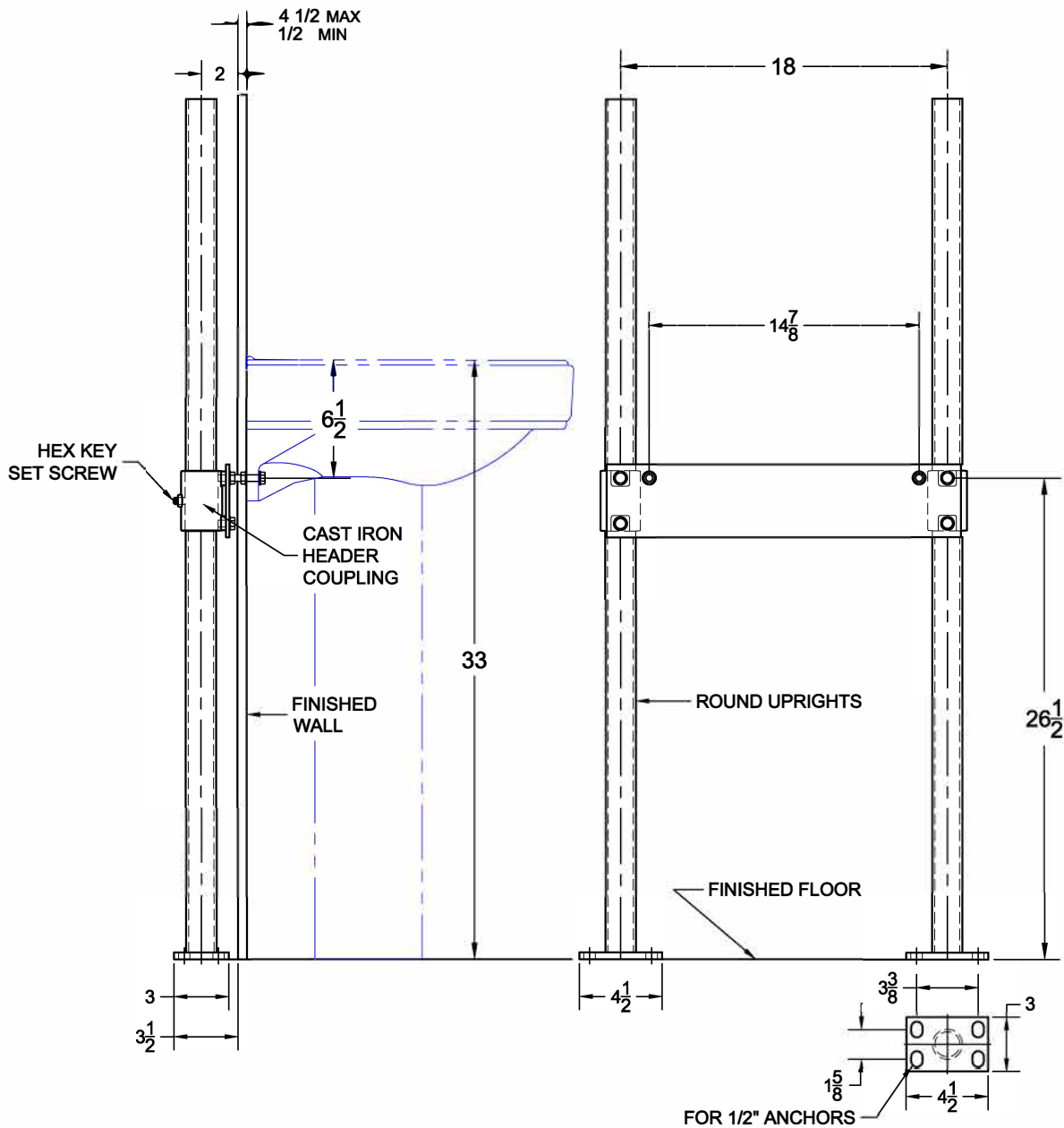

OPTIONS

Cat. No.	Type	Wt. Lbs.	Suffix	Description
<input type="checkbox"/> 401-M29	SGL	30.0	<input type="checkbox"/> M36	SQUARE UPRIGHTS

NOTE: CONTRACTOR MUST VERIFY DIMENSIONS WITH FIXTURE MANUFACTURER ROUGH-IN DATA
WADE DIVISION ACCEPTS NO RESPONSIBILITY FOR ANY INACCURACIES IN DRAWING

AutoCad.dwg