

Lavatory Carrier



510-NR

Exposed arm lavatory carrier with pipe uprights, welded base feet and level/lock hardware.

Arms - A.R.E. Coated Aluminum

FIXTURE

Manufacturer Crane

Name Yorkshire No. 1300V

Style Lavatory 1300S

1300H

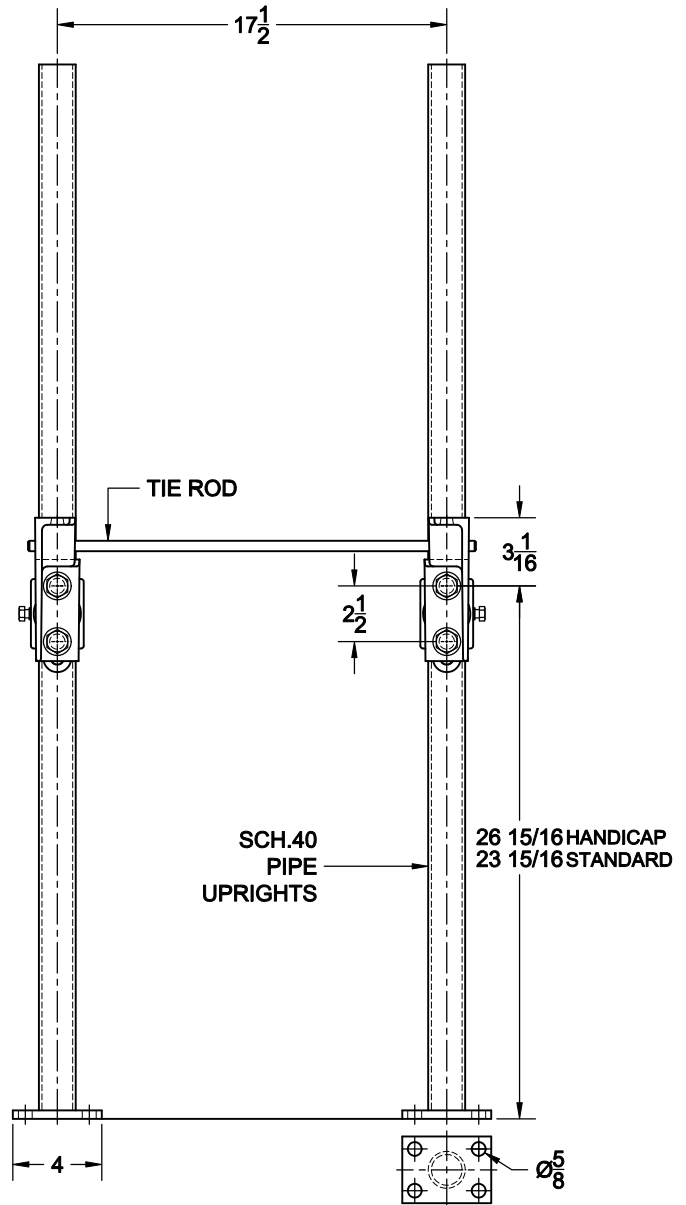
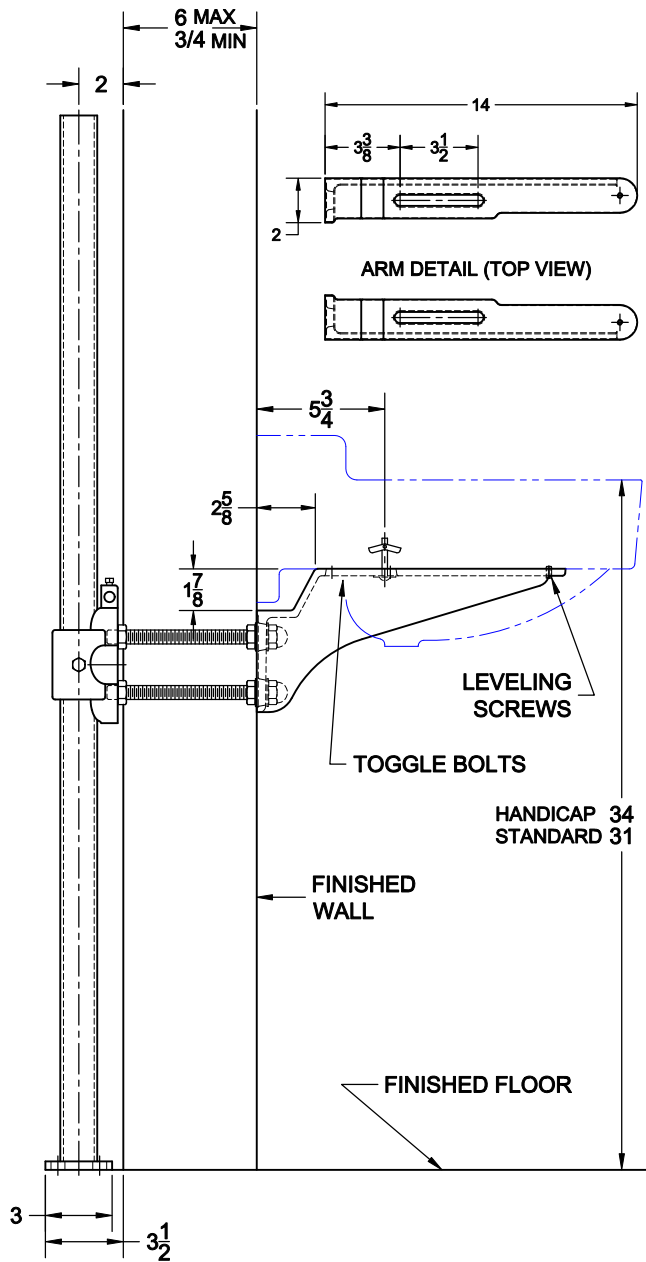

OPTIONS

Cat. No.	Type	Wt. Lbs.
510-NR	Single	38.0

Suffix	Description
M36	Rectangular Steel Uprights

AutoCad.dwg