

SINK CARRIER



Approval Date

623-SC161

FIXTURE

SINK CARRIER WITH PIPE UPRIGHTS, WELDED BASE FEET, A.R.E. HEAVY DUTY ARMS, HANGER SUPPORT PLATE & HARDWARE.

Manufacturer Willoughby

Name _____ No. CSSS3

Style Wash Station

Customer Approval

Wade Division / Tyler Pipe Assumes No Responsibility For Superseded or Voided Data

Job Location

Dimensional Data (Inches/mm) are Subject to Manufacturers Tolerance and Change Without Notice.

Job Name

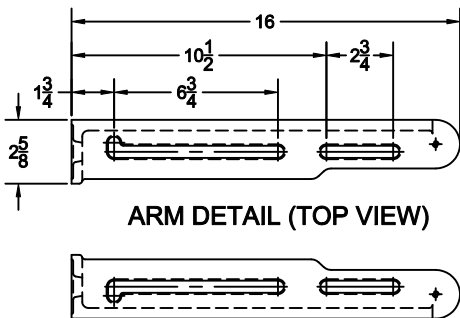
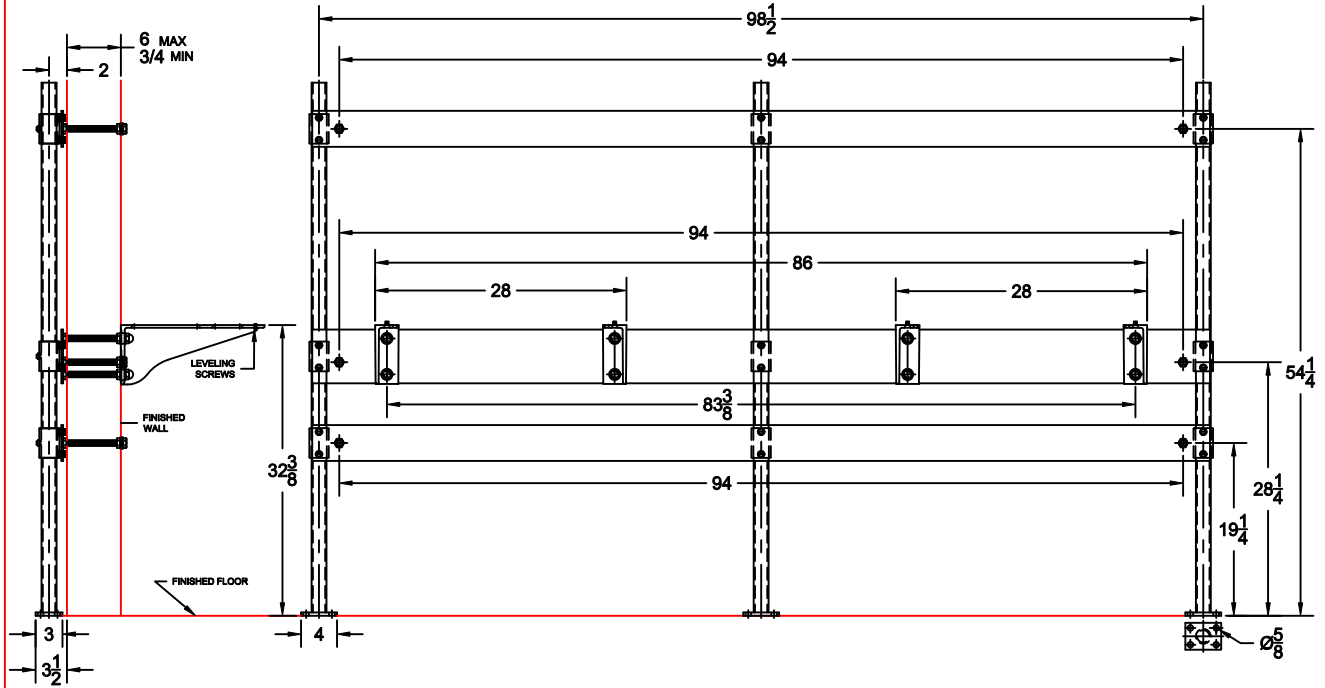

OPTIONS

Cat. No.	Type	Wt. Lbs.	Suffix	Description
<input type="checkbox"/> 623-SC161	SGL	59.0	<input type="checkbox"/> M36	SQUARE UPRIGHTS

NOTE: CONTRACTOR MUST VERIFY DIMENSIONS WITH FIXTURE MANUFACTURER ROUGH-IN DATA
 TYLER PIPE / WADE DIVISION ACCEPTS NO RESPONSIBILITY FOR ANY INACCURACIES IN DRAWING

AutoCad.dwg